

PARTS CATALOGUE

YZ125P '02 (5NY1)

YZ125P/YZ125
PARTS CATALOGUE
©2001 by Yamaha Motor Co., Ltd.
1st Edition, Jun. 2001
All rights reserved.
Any reprinting or unauthorized use
without the written permission of
Yamaha Motor Co., Ltd.
is expressly prohibited.
Printed in Japan

A2



A3

FOREWORD

This Parts Catalogue is related to the parts for the model(s) in the below frame. When you are ordering replacement parts, please refer to this Parts Catalogue and quote both part numbers and part names correctly.

YZ125P(5NY1/5NY4), YZ125(5NY2/5NY3)

1. Modifications or additions which have been made after issue of the Parts Catalogue will be announced in the Yamaha Parts News. It is advisable that you make necessary corrections to the Parts Catalogue according to the Yamaha Parts News.

2. Abbreviations
The Following abbreviations are used in this Parts Catalogue.

- “UR” Use specified parts number.
- “UN” Use as many as needed.
- “AP” Alternate Parts
- “LM” Local Made (Parts need to be ordered locally)
- “F#” Frame No. (Applicable machine No.)

3. Parts, which are to be supplied in an assembly, are listed with a dot(.) in front of the part name as shown below.

EXAMPLE

- CARBURETOR ASSY
- .JET, PILOT
- .NOZZLE, MAIN

4. Number of component for assembly
The numeral appearing to the right of each component part indicates the quantity of parts for each assembly unit.

EXAMPLE

PART NO.	DESCRIPTION	Q'TY	REMARKS
2F5-83310-60	FRONT FLASHER LIGHT ASSY	2	
115-83311-60	.BULB (6V-18W)	1	
1M1-83309-60	.REFLECTOR	1	

5. Applicable colors of graphics are represented in the “REMARKS” as shown below.

PART NO.	DESCRIPTION	Q'TY	REMARKS
2N4-24110-00-X5	FUEL TANK COMP.	1	MXR
3J1-24240-10	.GRAPHIC, FUEL TANK	1	FOR MXR

6. Applicable Serial No.

Engine Serial No.

Frame Serial No.

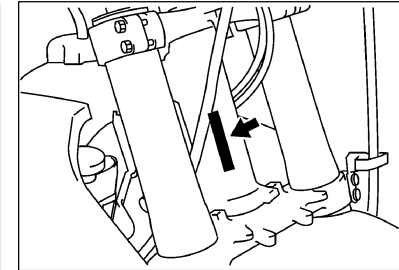
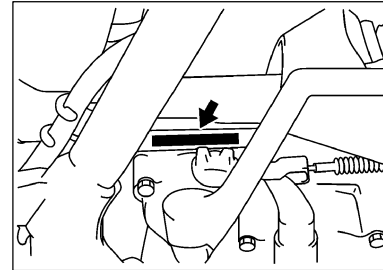

7. Note that the illustrations for reference in finding parts numbers, not to be used for assembling. When assembling, please use the applicable service manual.
8. The asterisk (*) before a reference number indicates modification items after the first edition.

MODEL LABEL

(1) A label called "Model Label" is affixed in the location as indicated in (3) below.
When using this parts catalogue, please be sure to cross-refer the "model code – production code No." in the catalogue to the "model code – production code No." indicated on the Model Label affixed onto the product concerned.

(2) "Model Label" Indication

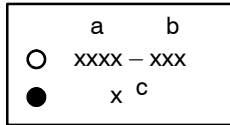

a: Model Type Code
b: Production Code No.
c: Colouring Type

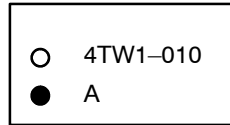

(3) Model Label Affixing Location

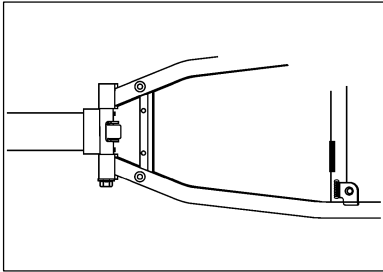

(4) Model Code – Production Code Number of Model Listed in This Parts Catalog

Model Code	Production Code No.	Country (destination)	Model Code	Production Code No.	Country (destination)
5NY1	010	USA			
	020	CANADA			
	030	SOUTH AFRICA			

(5) Colouring Information

Model Code	Colouring type code	Colour code	Colour Name	Abbreviation
5NY1	A	0583	DEEP PURPLISH BLUE SOLID E	DPBSE

CONTENTS

ENGINE

CYLINDER HEAD	B2
GOVERNOR	B4
CRANKSHAFT. PISTON	B5
WATER PUMP	B6
RADIATOR. HOSE	B7
INTAKE	B8
CARBURETOR	B9
EXHAUST	B13
CRANKCASE	B14
CRANKCASE COVER 1	B15
STARTER	C2
CLUTCH	C3
TRANSMISSION	C4
SHIFT CAM. FORK	C6
SHIFT SHAFT	C7

CHASSIS

FRAME	C8
FENDER	C9
SIDE COVER	C10
REAR ARM	C11
REAR SUSPENSION	C13
STEERING	C15
FRONT FORK	D2
FUEL TANK	D5
SEAT	D7
FRONT WHEEL	D8
FRONT BRAKE CALIPER	D9
REAR WHEEL	D10
REAR BRAKE CALIPER	D12

STEERING HANDLE. CABLE	D13
FRONT MASTER CYLINDER	D14
STAND. FOOTREST	D15
REAR MASTER CYLINDER	E2
GENERATOR	E3
HANDLE SWITCH. LEVER	E4
ELECTRICAL 1	E5
ALTERNATE (CHASSIS)	E6

FIG. 1 CYLINDER HEAD

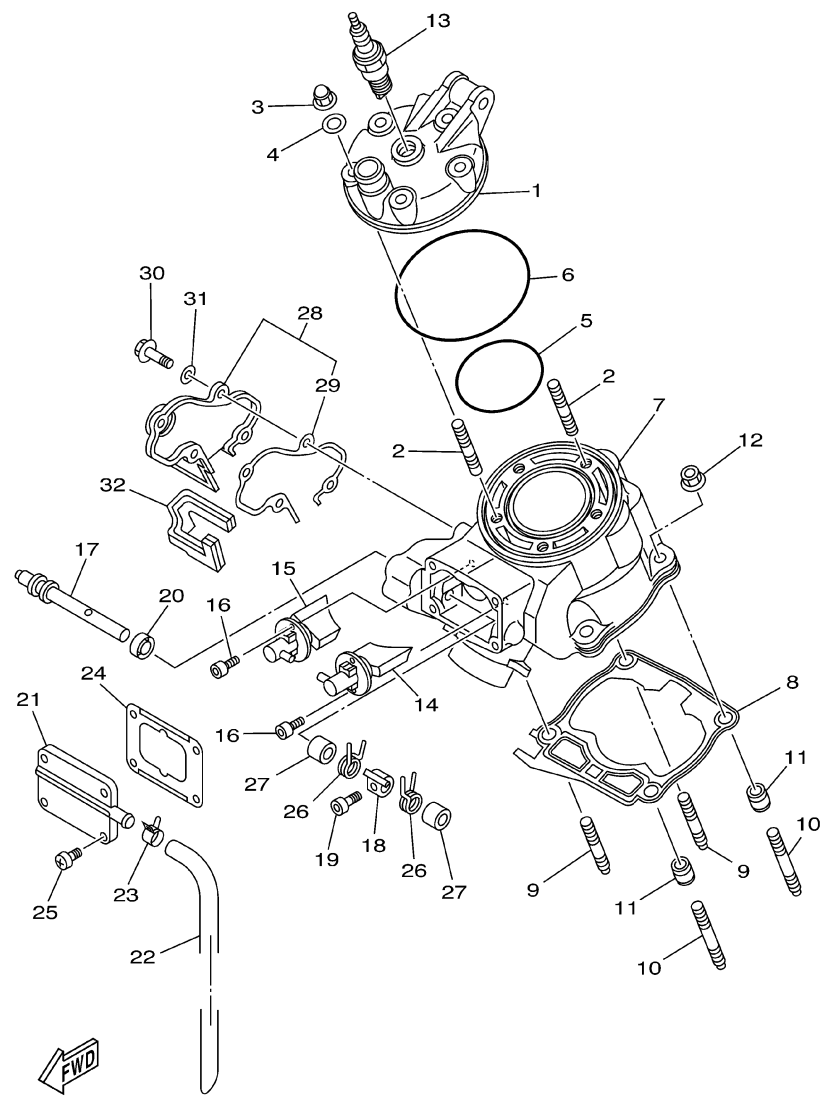

5NY1100-A010

REF. NO.	PART NO.	DESCRIPTION	5NY1	5NY2	5NY3	5NY4	REMARKS
1	5MV-11111-00	HEAD, CYLINDER 1	1	1	1	1	
2	90116-08394	BOLT, STUD	5	5	5	5	
3	90176-08026	NUT, CROWN	5	5	5	5	
4	90201-080L8	WASHER, PLATE	5	5	5	5	
5	93210-63442	O-RING	1	1	1	1	
6	93210-90785	O-RING	1	1	1	1	
7	5NY-11311-00	CYLINDER 1	1	1	1	1	
8	5DH-11351-01	GASKET, CYLINDER	1	1	1	1	
9	90116-08318	BOLT, STUD	2	2	2	2	
10	90116-08388	BOLT, STUD	2	2	2	2	
11	99590-10114	PIN, DOWEL	2	2	2	2	
12	90179-08299	NUT	4	4	4	4	
13	010-B9EG-PK4	PLUG, SPARK (NGK B9EG)	1				
14	5HD-1131D-10	VALVE ASSY	1	1	1	1	
15	5HD-1132D-10	VALVE ASSY 2	1	1	1	1	
16	91317-05012	BOLT	4	4	4	4	
17	5HD-1131V-00	SHAFT 1	1	1	1	1	
18	4SS-11832-00	LEVER, LINK	1	1	1	1	
19	91317-04008	BOLT	1	1	1	1	
20	93104-08040	OIL SEAL	1	1	1	1	
21	4SS-1131M-00	COVER	1	1	1	1	
22	4JY-11166-00	PIPE, BREATHER 1	1	1	1	1	
23	90467-13062	CLIP	1	1	1	1	
24	4JY-11354-02	GASKET	1	1	1	1	
25	98907-05016	SCREW, BIND	4	4	4	4	
26	90508-16134	SPRING, TORSION	2	2	2	2	

FIG. 2 GOVERNOR

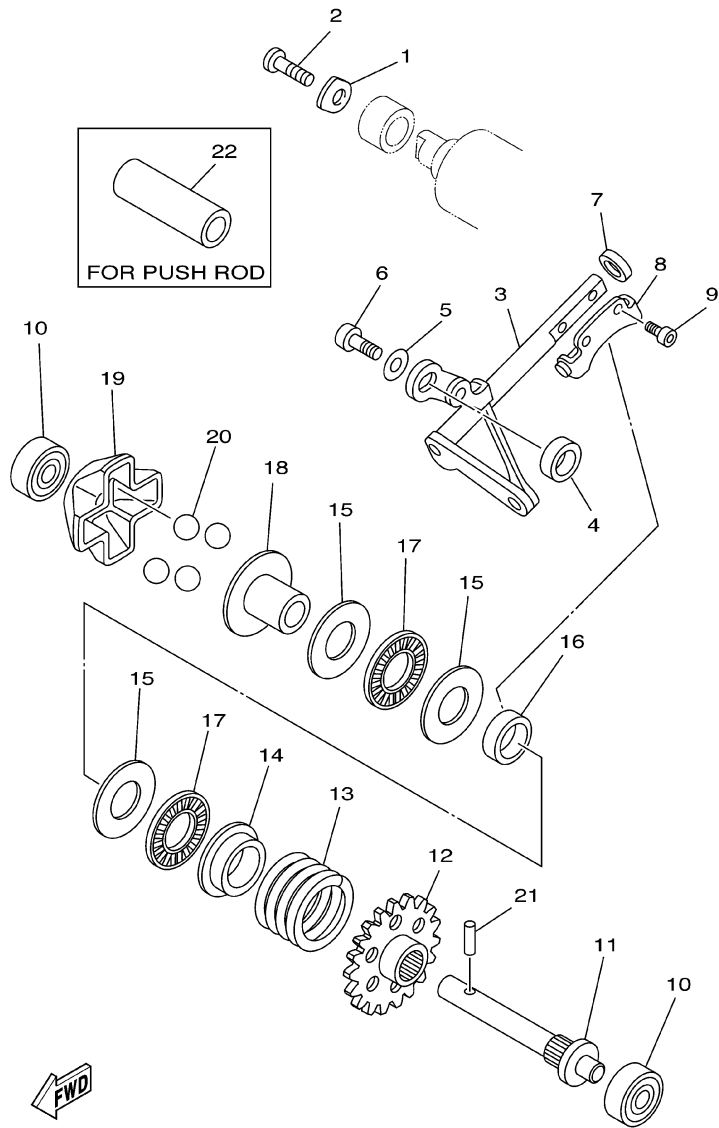

5NY1100-A020

REF. NO.	PART NO.	DESCRIPTION	5NY1	5NY2	5NY3	5NY4	REMARKS
1	4JY-11915-01	PLATE, THRUST 1	1	1	1	1	
2	98507-05012	SCREW, PAN HEAD	1	1	1	1	
3	4SS-11990-00	PUSH ROD ASSY	1	1	1	1	
4	90387-085E1	COLLAR	1	1	1	1	
5	90201-057H5	WASHER, PLATE	1	1	1	1	
6	97007-05012	BOLT	1	1	1	1	
7	93104-08040	OIL SEAL	1	1	1	1	
8	3JE-11922-01	FORK, GOVERNOR	1	1	1	1	
9	91317-04006	BOLT	2	2	2	2	
10	93300-60801	BEARING (B0060)	2	2	2	2	KOYO
11	5X4-11921-02	SHAFT, GOVERNOR	1	1	1	1	
12	5NY-11953-00	GEAR, GOVERNOR	1	1	1	1	
13	90501-26001	SPRING, COMPRESSION	1	1	1	1	
14	5CU-11952-00	PLATE	1	1	1	1	
15	90201-150U6	WASHER, PLATE	3	3	3	3	
16	90387-152F2	COLLAR	1	1	1	1	
17	93340-21505	BEARING	2	2	2	2	
18	5CU-11912-00	RETAINER, WEIGHT	1	1	1	1	
19	5CU-11911-00	RETAINER	1	1	1	1	
20	93507-16020	BALL	4	4	4	4	
21	93603-14240	PIN, DOWEL	1	1	1	1	
22	90387-107T9	COLLAR	1	1	1	1	AP

FIG. 3 CRANKSHAFT. PISTON

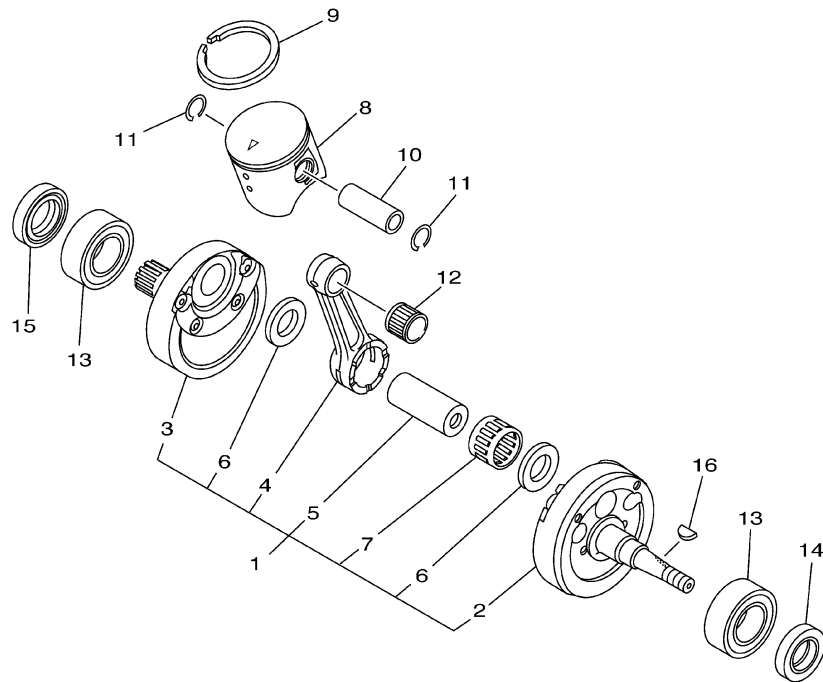

REF. NO.	PART NO.	DESCRIPTION	5NY1	5NY2	5NY3	5NY4	REMARKS
1	5MV-11400-00	CRANKSHAFT ASSY	1	1	1	1	
2	5MV-11410-00	.CRANKSHAFT	1	1	1	1	
3	5MV-11420-00	.CRANKSHAFT	1	1	1	1	
4	5MV-11651-00	.ROD, CONNECTING	1	1	1	1	
5	3JD-11681-10	.PIN, CRANK 1	1	1	1	1	
6	90209-22071	.WASHER	2	2	2	2	
7	93310-522P7	.BEARING	1	1	1	1	
8	5NY-11631-00-A0	PISTON (STD)	1	1	1	1	UR
	5NY-11631-00-B0	PISTON (STD)	1	1	1	1	UR
	5NY-11631-00-C0	PISTON (STD)	1	1	1	1	UR
	5NY-11631-00-D0	PISTON (STD)	1	1	1	1	UR
9	5NY-11611-00	RING, PISTON	1	1	1	1	
10	4XM-11633-10	PIN, PISTON	1	1	1	1	
11	93450-16068	CIRCLIP	2	2	2	2	
12	93310-21510	BEARING	1	1	1	1	
13	93306-37204	BEARING (63/22SH2-9TC4)	2	2	2	2	KOYO
14	93102-20485	OIL SEAL	1	1	1	1	
15	93102-30008	OIL SEAL	1	1	1	1	
16	90280-03017	KEY, WOODRUFF	1	1	1	1	



5NY1100-A030

FIG. 4 WATER PUMP

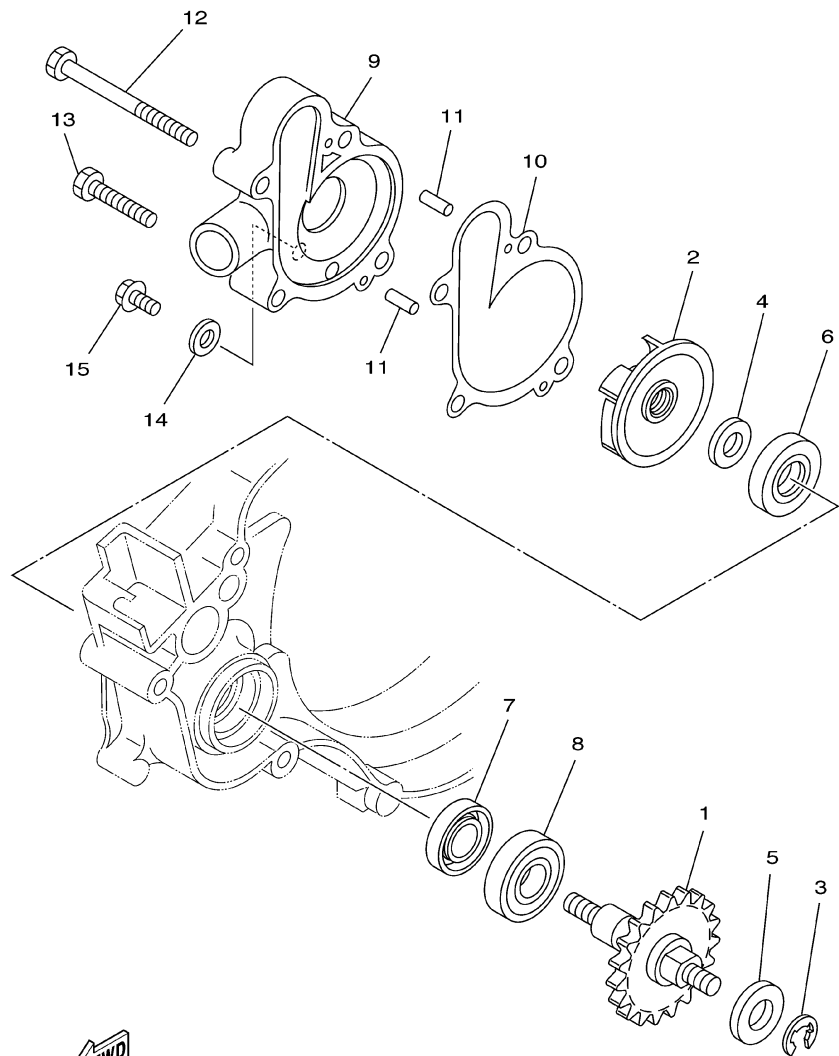

FWD
5DH1100-8040

REF. NO.	PART NO.	DESCRIPTION	5NY1	5NY2	5NY3	5NY4	REMARKS
1	5DH-12459-01	GEAR, IMPELLER SHAFT	1	1	1	1	
2	5DH-12451-00	IMPELLER, WATER PUMP	1	1	1	1	
3	99001-06600	CIRCLIP	1	1	1	1	
4	90201-083P5	WASHER, PLATE	1	1	1	1	
5	90201-08784	WASHER, PLATE	1	1	1	1	
6	93109-11073	OIL SEAL	1	1	1	1	
7	93102-12106	OIL SEAL (SD 12-22-5 HS)	1	1	1	1	
8	93306-00105	BEARING (B6001)	1	1	1	1	
9	4JY-12422-01	COVER, HOUSING	1	1	1	1	
10	4JY-12428-00	GASKET, HOUSING COVER 2	1	1	1	1	
11	93604-10011	PIN, DOWEL	2	2	2	2	
12	95027-06065	BOLT, FLANGE	2	2	2	2	
13	95027-06030	BOLT, FLANGE	2	2	2	2	
14	90430-06014	GASKET	1	1	1	1	
15	95027-06010	BOLT, FLANGE	1	1	1	1	

FIG. 5 RADIATOR. HOSE

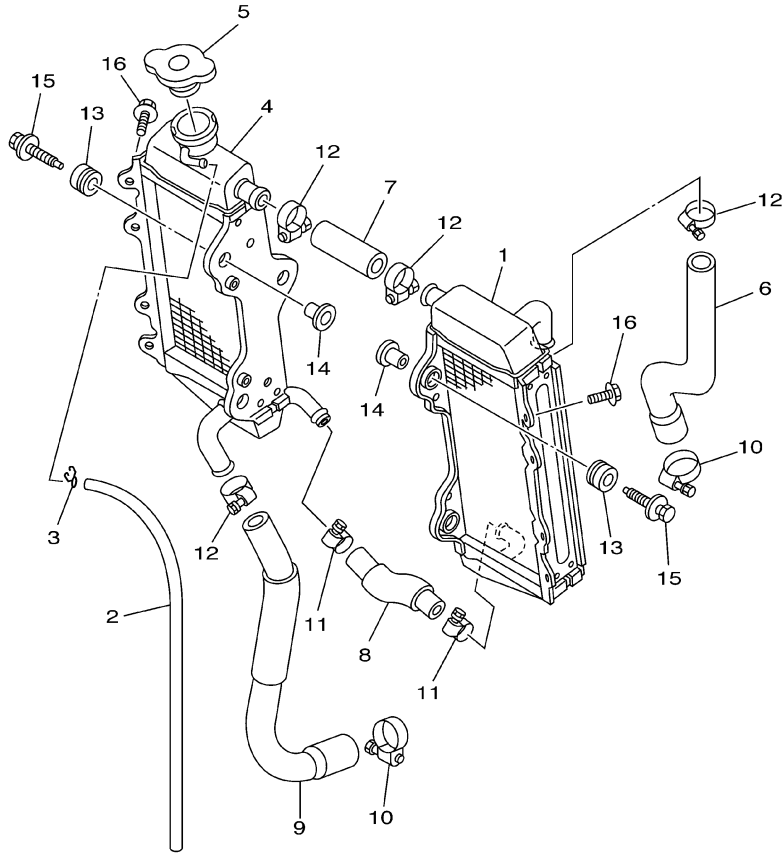

REF. NO.	PART NO.	DESCRIPTION	5NY1	5NY2	5NY3	5NY4	REMARKS
1	5NY-1240A-00	RADIATOR ASSY	1	1	1	1	
2	91A20-05065	TUBE, FLEXIBLE VINYL	1	1	1	1	
3	90467-09006	CLIP	1	1	1	1	
4	5NY-12461-00	RADIATOR ASSY	1	1	1	1	
5	5HD-12462-00	CAP, RADIATOR	1	1	1	1	
6	5NY-12481-00	PIPE 1	1	1	1	1	
7	5NY-12482-00	PIPE 2	1	1	1	1	
8	5NY-12483-00	PIPE 3	1	1	1	1	
9	5NY-12484-00	PIPE 4	1	1	1	1	
10	90450-28014	HOSE CLAMP ASSY	2	2	2	2	
11	90450-22017	HOSE CLAMP ASSY	2	2	2	2	
12	90450-25037	HOSE CLAMP ASSY	4	4	4	4	
13	90480-15528	GROMMET	6	6	6	6	
14	90387-0614M	COLLAR	6	6	6	6	
15	90119-06038	BOLT, WITH WASHER	6	6	6	6	
16	95827-06010	BOLT, FLANGE	2	2	2	2	



5NY1100-A050

FIG. 6 INTAKE

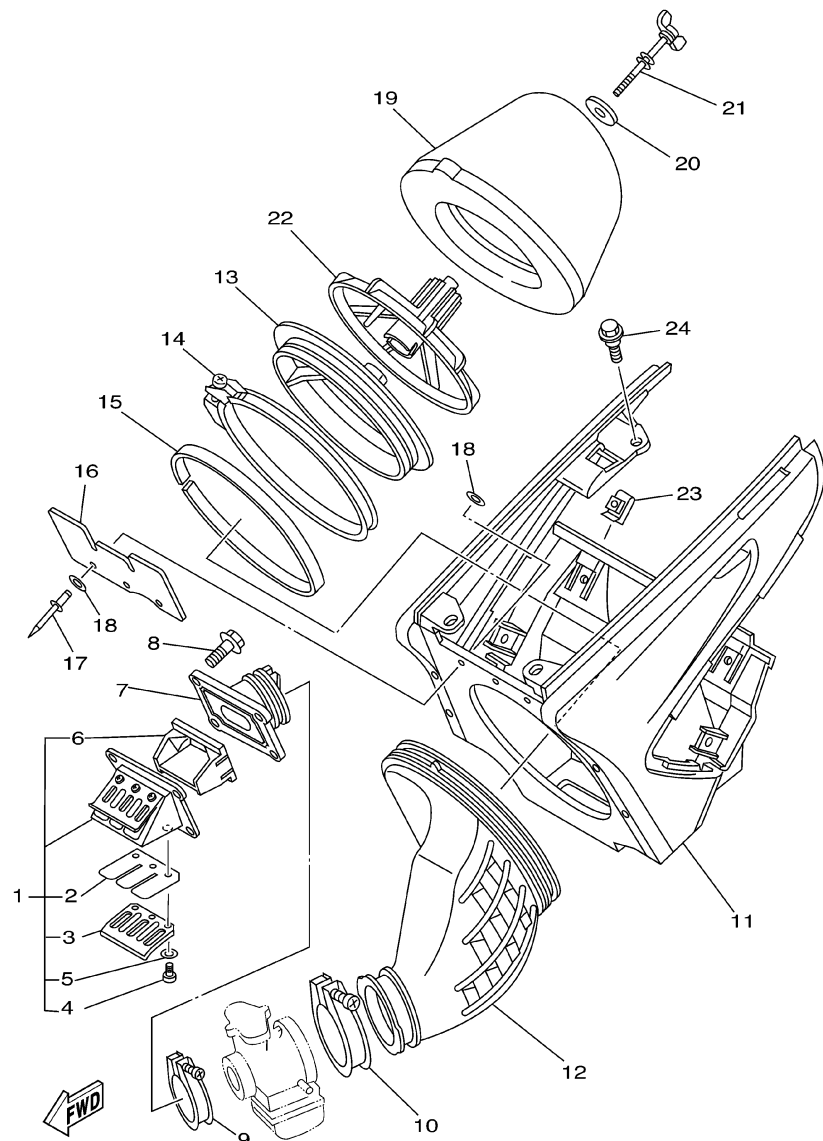

5NY1100-A060

REF. NO.	PART NO.	DESCRIPTION	5NY1	5NY2	5NY3	5NY4	REMARKS
1	5MV-13610-00	REED VALVE ASSY	1	1	1	1	
2	5MV-13613-00	.REED, VALVE	2	2	2	2	
3	5MV-13616-00	.STOPPER, REED VALVE	2	2	2	2	
4	98507-03006	.SCREW, PAN HEAD	6	6	6	6	
5	92907-03100	.WASHER	6	6	6	6	
6	5MV-13625-00	.SPACER, REED VALVE	1	1	1	1	
7	5MV-13565-10	JOINT, CARBURETOR	1	1	1	1	
8	95027-06020	BOLT, FLANGE	4	4	4	4	
9	90450-51070	HOSE CLAMP ASSY	1	1	1	1	
10	90450-70072	HOSE CLAMP ASSY	1	1	1	1	
11	5NY-14401-00	AIR CLEANER CASE ASSY	1	1	1	1	
12	5NY-14453-00	JOINT, AIR CLEANER 1	1	1	1	1	
13	5NY-14459-00	HOLDER, GUIDE	1	1	1	1	
14	5NY-14455-00	BAND	1	1	1	1	
15	5NY-14442-00	SPACER	1	1	1	1	
16	5NY-14417-00	COVER 1	1	1	1	1	
17	90267-32070	RIVET, BLIND	3	3	3	3	
18	90201-03313	WASHER, PLATE	6	6	6	6	
19	4XM-14451-00	ELEMENT, AIR CLEANER	1	1	1	1	
20	90209-06096	WASHER	1	1	1	1	
21	90122-06035	BOLT, WING	1	1	1	1	
22	3JD-14458-01	GUIDE	1	1	1	1	
23	90183-06023	NUT, SPRING	4	4	4	4	
24	90109-067F4	BOLT	4	4	4	4	

FIG. 7 CARBURETOR

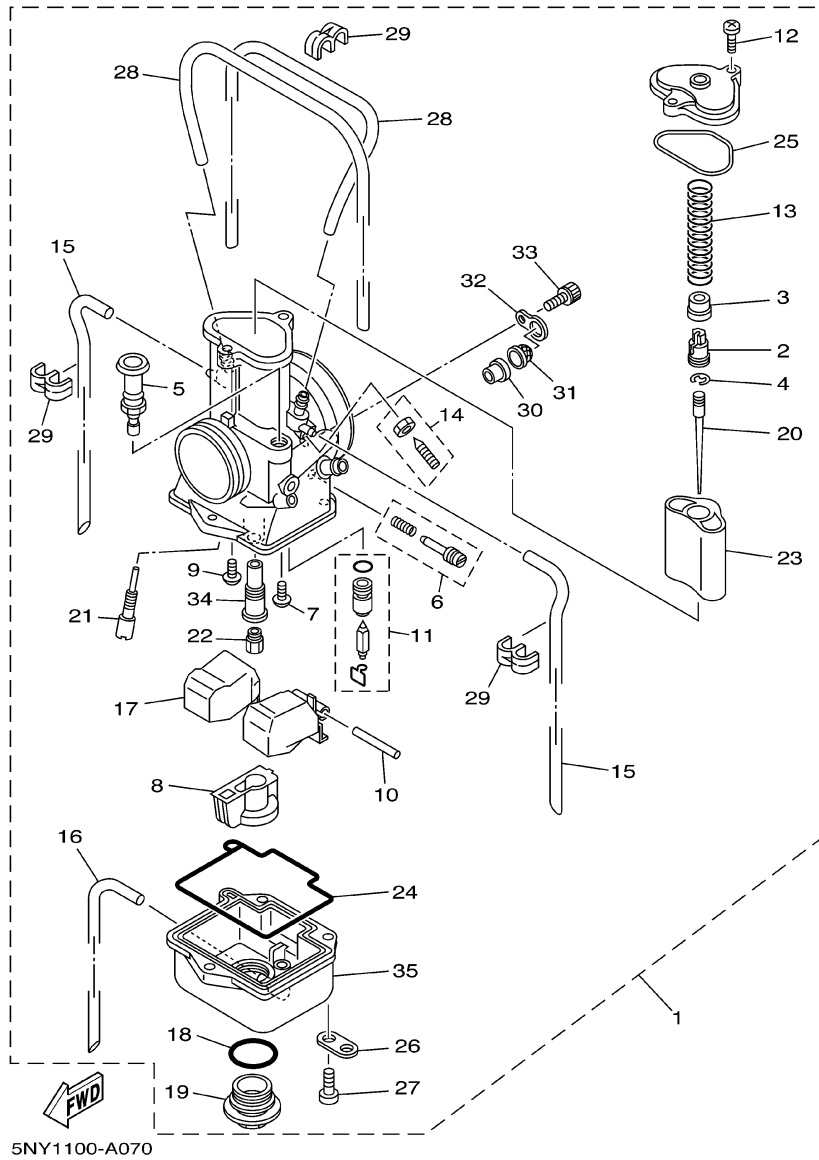

REF. NO.	PART NO.	DESCRIPTION	5NY1	5NY2	5NY3	5NY4	REMARKS
1	5NY-14101-00	CARBURETOR ASSY	1				
2	5HD-14261-00	.HOLDER	1	1	1	1	
3	4PE-14194-00	.RING	1	1	1	1	
4	3MA-14159-00	.CLIP	1	1	1	1	
5	3JE-14171-00	.PLUNGER, STARTER	1	1	1	1	
6	3JD-14104-00	.AIR SCREW SET	1	1	1	1	
7	1FN-14565-00	.SCREW	1	1	1	1	
8	5ET-14261-01	.HOLDER	1	1	1	1	
9	98507-04008	.SCREW, PAN HEAD	1	1	1	1	
10	353-14186-00	.PIN, FLOAT	1	1	1	1	
11	4PE-14107-38	.NEEDLE VALVE SET	1	1	1	1	
12	98507-04014	.SCREW, PAN HEAD	2	2	2	2	
13	4PE-14131-00	.SPRING, THROTTLE VALVE	1	1	1	1	
14	4PE-14103-00	.THROTTLE SCREW SET	1	1	1	1	
15	5ET-14197-00	.PIPE	2	2	2	2	
16	10V-14196-00	.PIPE	1	1	1	1	
17	5ET-14185-00	.FLOAT	1	1	1	1	
18	2K6-14147-00	.O-RING	1	1	1	1	
19	5ET-14115-00	.PLUG, SCREW	1	1	1	1	
20	284-14116-E4	.NEEDLE (6CHY5-79)	1			1	STD
	284-14116-E2	.NEEDLE (6CHY5-77)	1				
	284-14116-E5	.NEEDLE (6CHY5-80)	1				
	284-14116-E3	.NEEDLE (6CHY5-78)	1			1	AP

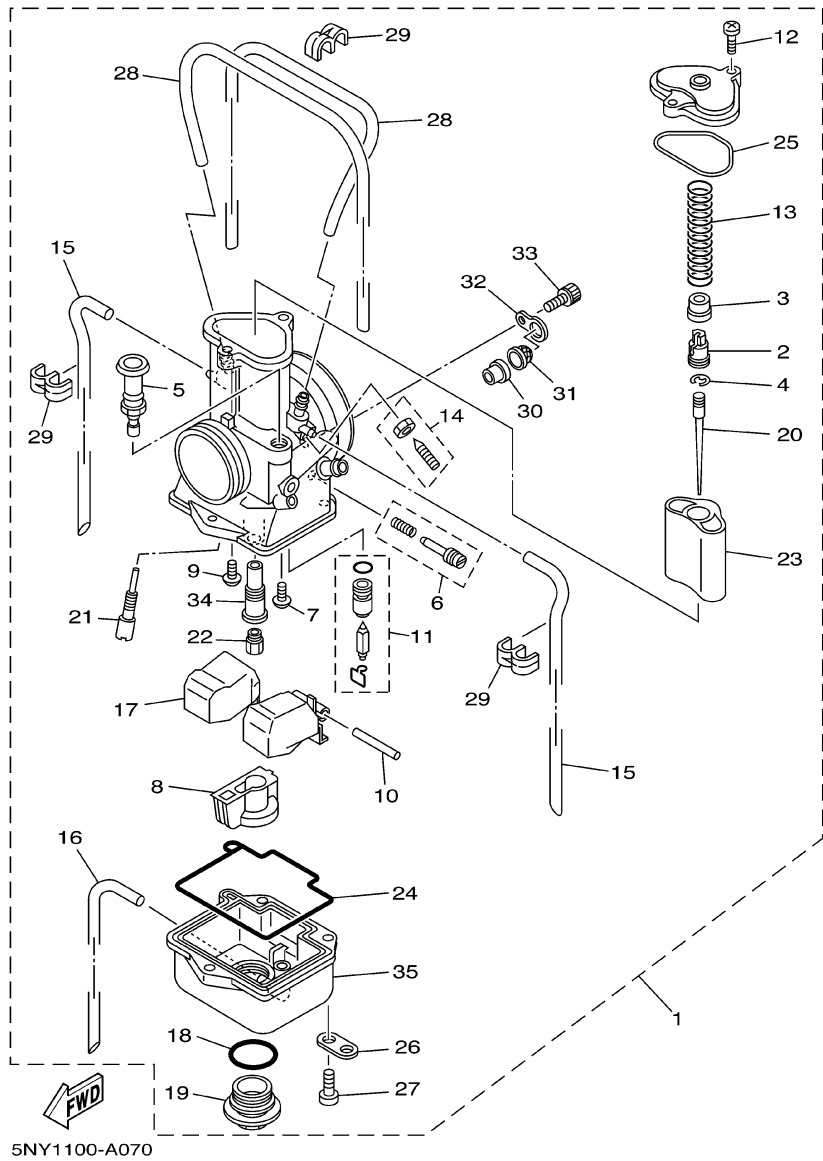
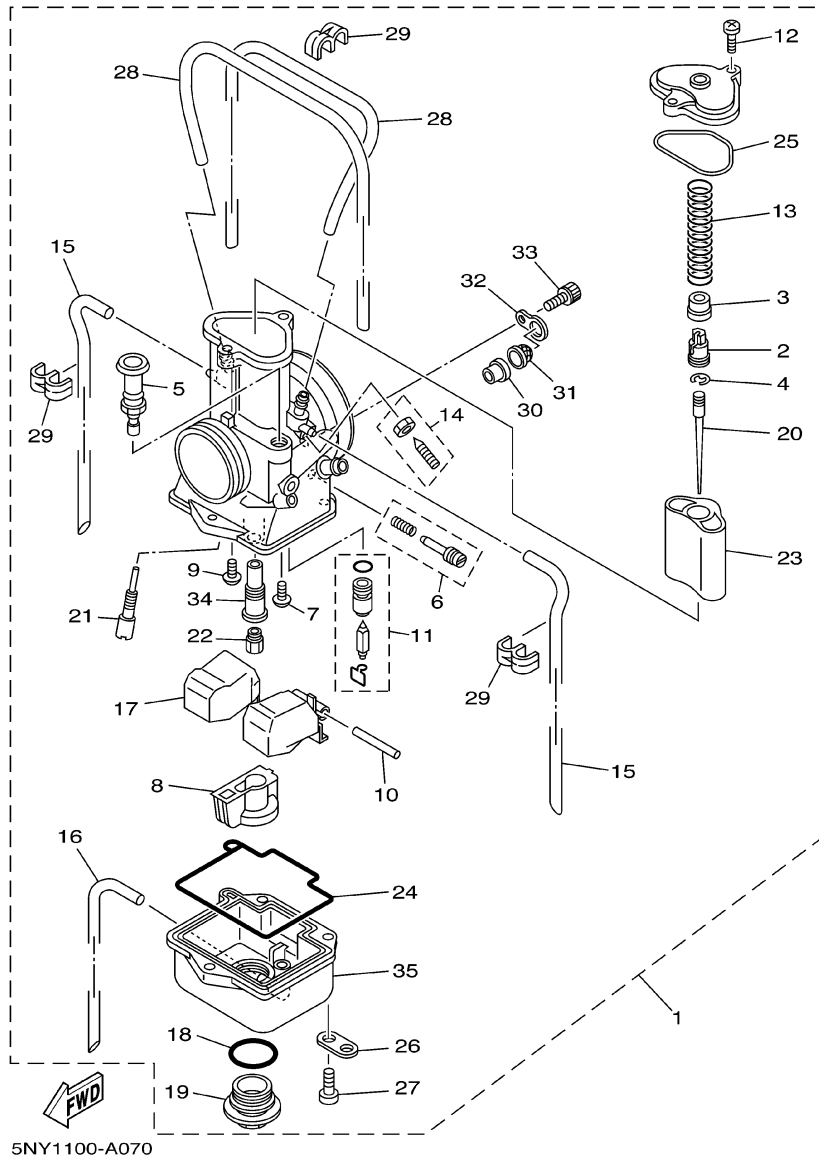

FIG. 7 CARBURETOR

REF. NO.	PART NO.	DESCRIPTION	5NY1	5NY2	5NY3	5NY4	REMARKS
20	284-14116-E6	.NEEDLE (6CHY5-81)	1			1	AP
	284-14116-F2	.NEEDLE (6CHY6-77)	1			1	AP
	284-14116-F3	.NEEDLE (6CHY6-78)	1			1	AP
	284-14116-F4	.NEEDLE (6CHY6-79)	1			1	AP
	284-14116-F5	.NEEDLE (6CHY6-80)	1			1	AP
	284-14116-F6	.NEEDLE (6CHY6-81)	1			1	AP

21	4KM-14142-30	.JET, PILOT (#30)	1	1	1	1	STD
	4KM-14142-20	.JET, PILOT (#20)	1	1	1	1	AP
	4KM-14142-22	.JET, PILOT (#22.5)	1	1	1	1	AP

FIG. 7 CARBURETOR



REF. NO.	PART NO.	DESCRIPTION	5NY1	5NY2	5NY3	5NY4	REMARKS
21	4KM-14142-25	.JET, PILOT (#25)	1	1	1	1	AP
	4KM-14142-27	.JET, PILOT (#27.5)	1	1	1	1	AP
	4KM-14142-32	.JET, PILOT (#32.5)	1	1	1	1	AP
	4KM-14142-35	.JET, PILOT (#35)	1	1	1	1	AP
	4KM-14142-37	.JET, PILOT (#37.5)	1	1	1	1	AP
	4KM-14142-40	.JET, PILOT (#40)	1	1	1	1	AP
22	137-14143-84	.JET, MAIN (#420)	1		1	1	STD
	137-14143-86	.JET, MAIN (#430)	1				
	137-14143-78	.JET, MAIN (#390)	1	1	1	1	AP
	137-14143-80	.JET, MAIN (#400)	1	1	1	1	AP
	137-14143-82	.JET, MAIN (#410)	1	1	1	1	AP
	137-14143-88	.JET, MAIN (#440)	1	1	1	1	AP
	137-14143-90	.JET, MAIN (#450)	1	1	1	1	AP
	137-14143-92	.JET, MAIN (#460)	1	1	1	1	AP
23	5NY-14112-57	.VALVE, THROTTLE 1	1	1	1	1	STD
	5NY-14112-55	.VALVE, THROTTLE 1	1	1	1	1	AP
	5NY-14112-60	.VALVE, THROTTLE 1	1	1	1	1	AP
24	5ET-1416A-00	.O-RING	1	1	1	1	
25	5ET-14147-00	.O-RING	1	1	1	1	
26	51R-14146-00	.PLATE	1	1	1	1	
27	98502-05014	.SCREW, PAN HEAD	3	3	3	3	
28	2HH-14197-00	.PIPE	2	2	2	2	
29	87M-14137-00	.CLIP	3	3	3	3	
30	5MV-14194-00	.RING	1	1	1	1	
31	5MV-24514-00	.NET, FILTER 1	1	1	1	1	

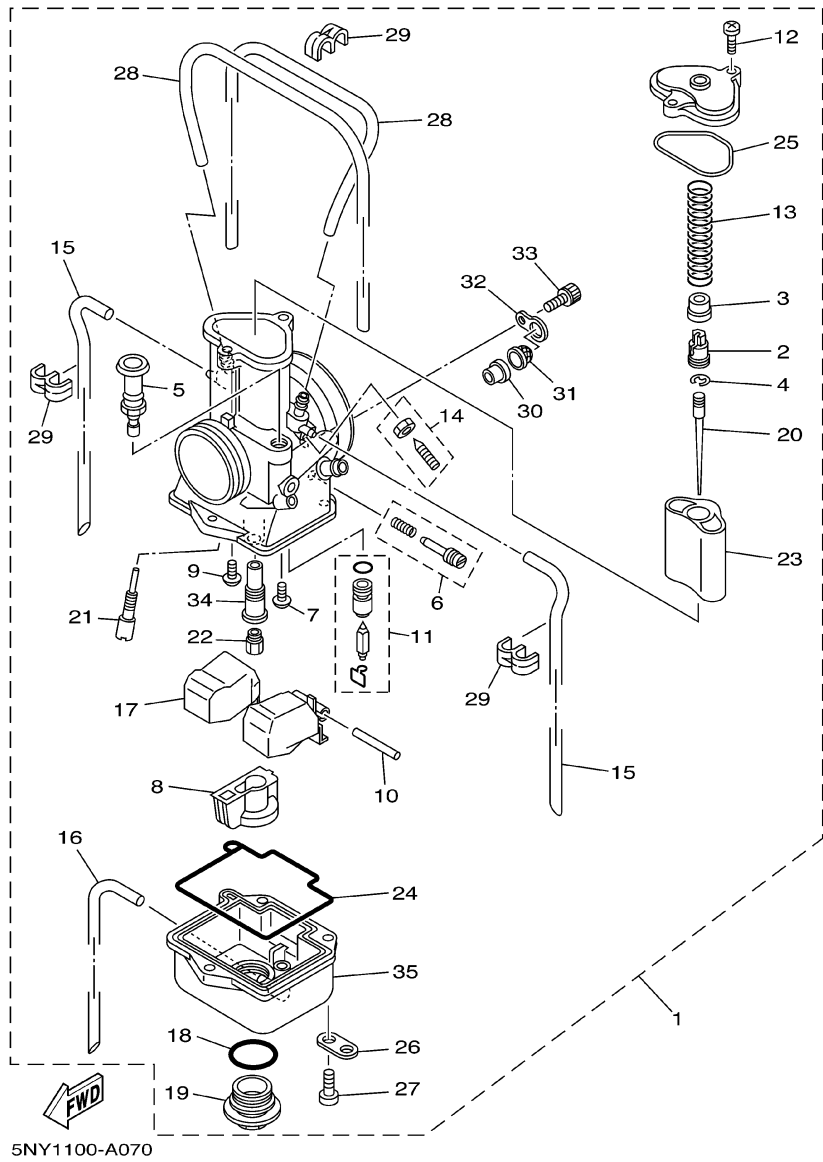
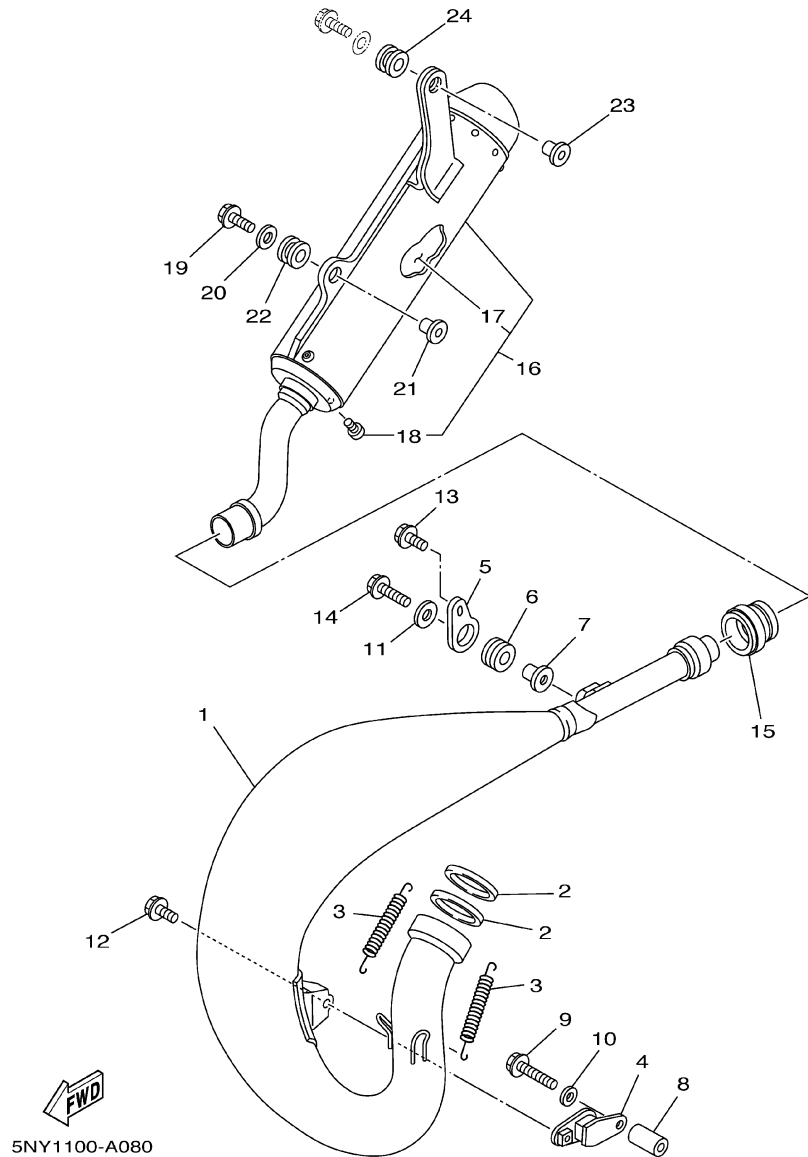

FIG. 7 CARBURETOR

REF. NO.	PART NO.	DESCRIPTION	5NY1	5NY2	5NY3	5NY4	REMARKS
32	5MV-14146-00	.PLATE	1	1	1	1	
33	5MV-14216-00	.SCREW	1	1	1	1	
34	5MV-14261-00	.HOLDER	1	1	1	1	
35	5NY-14181-00	.BODY, FLOAT CHAMBER 1	1		1	1	

FIG. 8 EXHAUST



REF. NO.	PART NO.	DESCRIPTION	5NY1	5NY2	5NY3	5NY4	REMARKS
1	5NY-14610-00	EXHAUST PIPE ASSY 1	1	1	1	1	
2	5MV-14642-00	SEAL, EXHAUST	2	2	2	2	
3	90507-20052	SPRING, TENSION	2	2	2	2	
4	565-14771-00	STAY, MUFFLER 1	1	1	1	1	
5	5CU-14771-00	STAY, MUFFLER 1	1	1	1	1	
6	90480-16561	GROMMET	1	1	1	1	
7	90387-063G3	COLLAR	1	1	1	1	
8	90387-062W7	COLLAR	1	1	1	1	
9	95027-06045	BOLT, FLANGE	1	1	1	1	
10	90201-06060	WASHER, PLATE	1	1	1	1	
11	90201-06071	WASHER, PLATE	1	1	1	1	
12	95027-06012	BOLT, FLANGE	1	1	1	1	
13	90119-06192	BOLT, WITH WASHER	1	1	1	1	
14	95027-06025	BOLT, FLANGE	1	1	1	1	
15	4JY-14615-00	JOINT, EXHAUST 1	1	1	1	1	
16	5NY-14753-00	SILENCER, EXHAUST	1	1	1	1	
17	5NY-1469A-00	.FIBER	1	1	1	1	
18	92017-06010	.BOLT, BUTTON HEAD	2	2	2	2	
19	95027-06025	BOLT, FLANGE	1	1	1	1	
20	90201-06071	WASHER, PLATE	1	1	1	1	
21	90387-063G3	COLLAR	1	1	1	1	
22	90480-16561	GROMMET	1	1	1	1	
23	90387-06039	COLLAR	1	1	1	1	
24	90480-16404	GROMMET	1	1	1	1	

FIG. 9 CRANKCASE

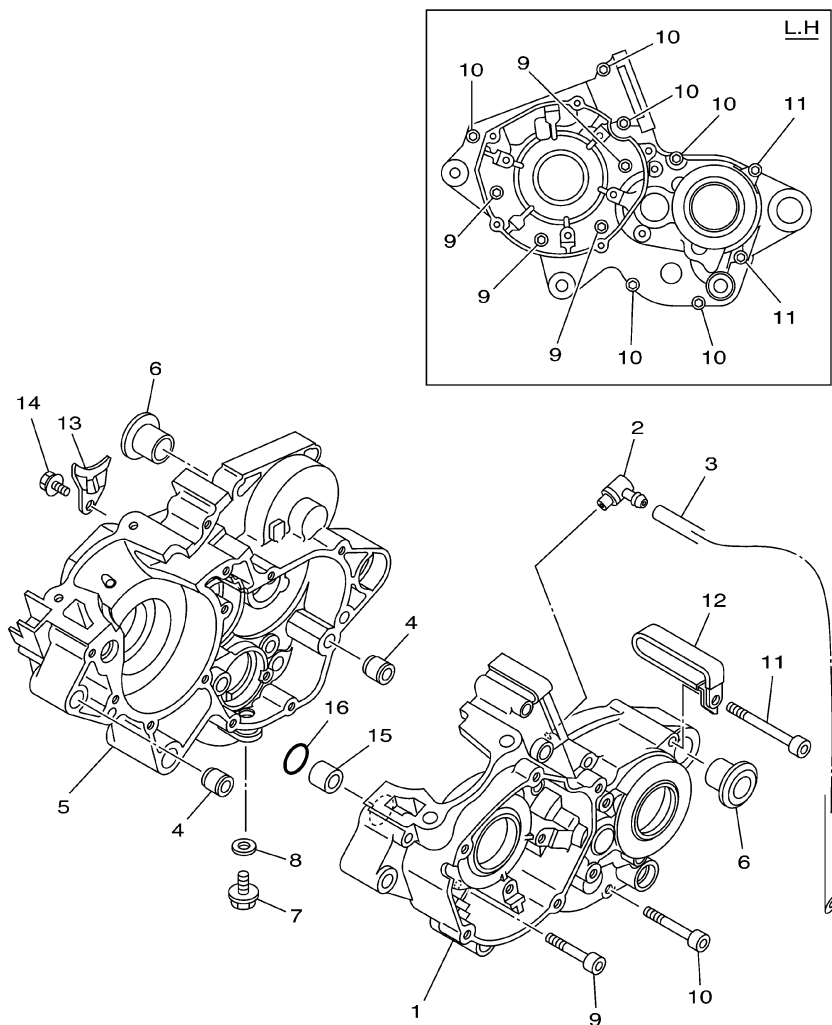

REF. NO.	PART NO.	DESCRIPTION	5NY1	5NY2	5NY3	5NY4	REMARKS
1	5NY-15111-00	CRANKCASE 1	1	1	1	1	
2	353-13115-01	CONNECTOR, SUCTION PIPE	1	1	1	1	
3	90445-08605	HOSE	1	1	1	1	
4	93612-16254	PIN, DOWEL	2	2	2	2	
5	5NY-15121-00	CRANKCASE 2	1	1	1	1	
6	90387-18006	COLLAR	2	2	2	2	
7	90340-12059	PLUG, STRAIGHT SCREW	1	1		1	
8	90430-12227	GASKET	1	1	1	1	
9	91317-06045	BOLT	4	4	4	4	
10	91317-06055	BOLT	6	6	6	6	
11	91317-06070	BOLT	2	2	2	2	
12	90461-10136	CLAMP	1	1	1	1	
13	3R4-15118-00	HOLDER	1	1	1	1	
14	90105-06556	BOLT, FLANGE	1	1	1	1	
15	99590-17016	PIN, DOWEL	1	1	1	1	
16	93210-16314	O-RING	1	1	1	1	



5NY1100-A090

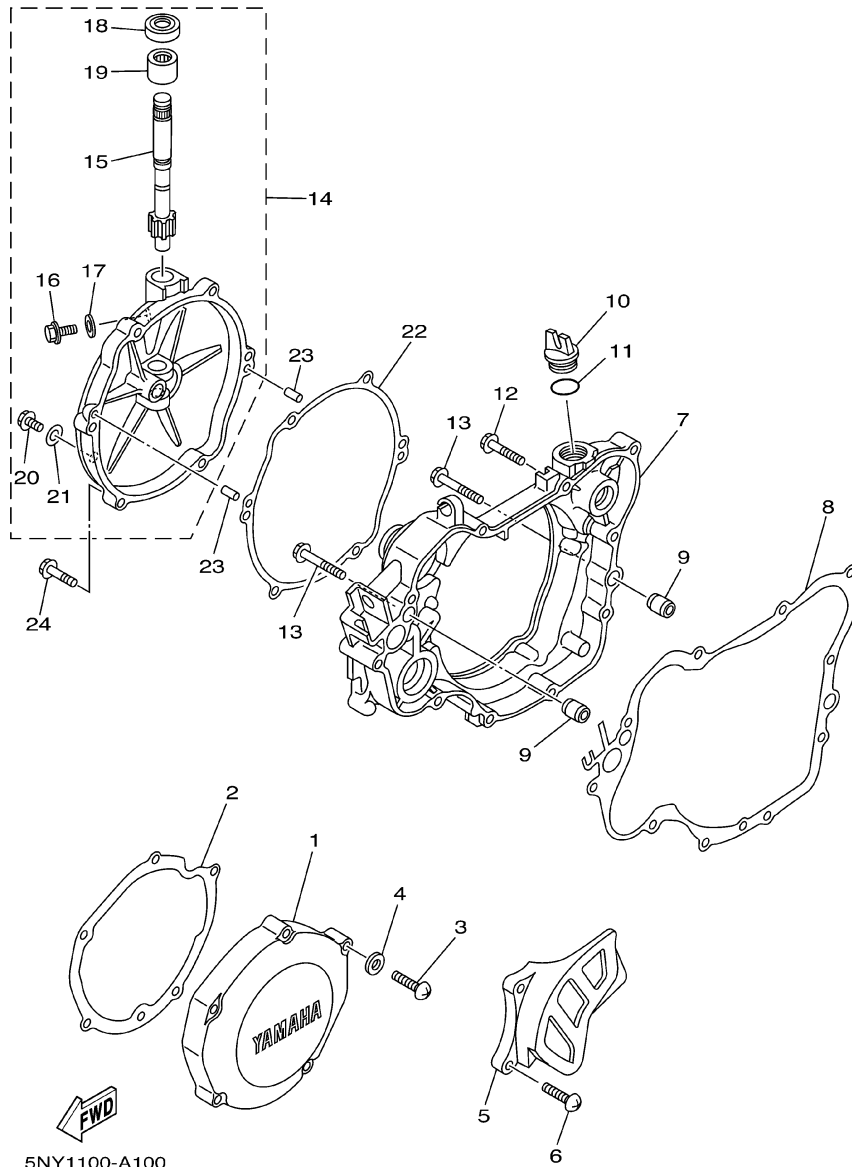

5NY1100-A100

FIG. 10 CRANKCASE COVER 1

REF. NO.	PART NO.	DESCRIPTION	5NY1	5NY2	5NY3	5NY4	REMARKS
1	4JY-15411-00	COVER, CRANKCASE 1	1	1	1	1	
2	4JY-15451-10	GASKET, CRANKCASE COVER 1	1	1	1	1	
3	98507-06030	SCREW, PAN HEAD	5	5	5	5	
4	92907-06600	WASHER, PLATE	5	5	5	5	
5	4EX-15421-00	COVER, CRANKCASE 2	1	1	1	1	
6	98507-06016	SCREW, PAN HEAD	2	2	2	2	
7	4JY-15431-13	COVER, CRANKCASE 3	1	1	1	1	
8	4JY-15462-00	GASKET, CRANKCASE COVER 3	1	1	1	1	
9	99530-10114	PIN, DOWEL	2	2	2	2	
10	3Y1-15363-00	PLUG, OIL	1	1	1	1	
11	93210-19123	O-RING	1	1	1	1	
12	95027-06030	BOLT, FLANGE	6	6	6	6	
13	95027-06040	BOLT, FLANGE	2	2	2	2	
14	5NY-15490-00	COVER ASSY	1	1	1	1	
15	4EX-16382-10	.AXLE, PUSH LEVER	1	1	1	1	
16	90109-06418	.BOLT	1	1	1	1	
17	90430-06014	.GASKET	1	1	1	1	
18	93102-12224	.OIL SEAL	1	1	1	1	
19	93315-11206	.BEARING	1	1	1	1	
20	95027-06010	.BOLT, FLANGE	1	1	1	1	
21	90430-06014	.GASKET	1	1	1	1	
22	4JY-15463-01	GASKET, CARBURETOR COVER 2	1	1	1	1	
23	93604-10011	PIN, DOWEL	2	2	2	2	
24	95027-06025	BOLT, FLANGE	6	6	6	6	

FIG. 11 STARTER

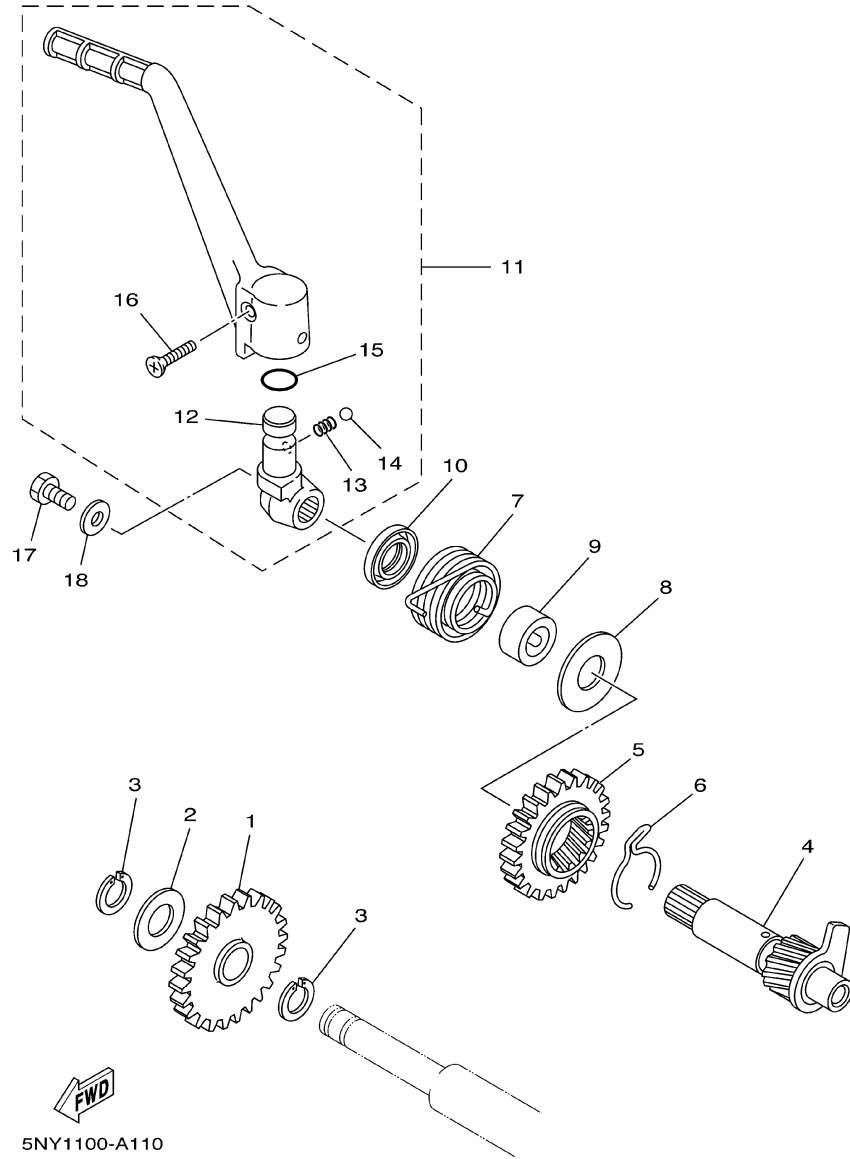

5NY1100-A110

REF. NO.	PART NO.	DESCRIPTION	5NY1	5NY2	5NY3	5NY4	REMARKS
1	1LX-15651-00	GEAR, KICK IDLE	1	1	1	1	
2	90201-152H7	WASHER, PLATE	1	1	1	1	
3	93440-15012	CIRCLIP	2	2	2	2	
4	1LX-15660-03	KICK AXLE ASSY	1	1	1	1	
5	1LX-15641-00	GEAR, KICK	1	1	1	1	
6	90468-26048	CLIP	1	1	1	1	
7	90508-26450	SPRING, TORSION	1	1	1	1	
8	90201-171G4	WASHER, PLATE	1	1	1	1	
9	90560-17279	SPACER	1	1	1	1	
10	93102-17263	OIL SEAL	1	1	1	1	
11	4DB-15620-03	KICK CRANK ASSY	1	1	1	1	
12	4DB-15621-03	.BOSS, KICK CRANK	1	1	1	1	
13	90501-12081	.SPRING, COMPRESSION	1	1	1	1	
14	93507-32009	.BALL	1	1	1	1	
15	93210-15171	.O-RING	1	1	1	1	
16	90152-06010	.SCREW, COUNTERSUNK	1	1	1	1	
17	97027-06012	BOLT	1	1	1	1	
18	90201-06060	WASHER, PLATE	1	1	1	1	

FIG. 12 CLUTCH

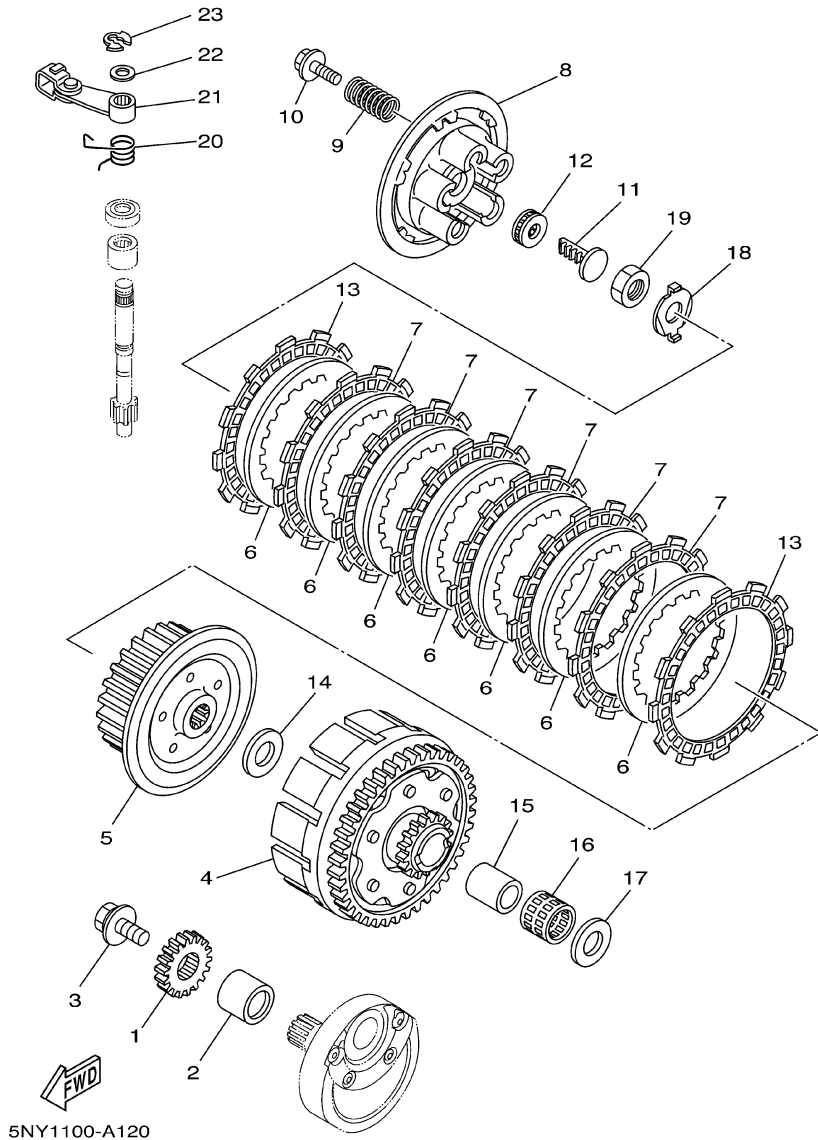

5NY1100-A120

REF. NO.	PART NO.	DESCRIPTION	5NY1	5NY2	5NY3	5NY4	REMARKS
1	3XJ-16111-00	GEAR, PRIMARY DRIVE	1	1	1	1	
2	90387-20007	COLLAR	1	1	1	1	
3	90105-10445	BOLT, FLANGE	1	1	1	1	
4	5NY-16150-00	PRIMARY DRIVEN GEAR COMP.	1	1	1	1	
5	5NY-16371-00	BOSS, CLUTCH	1	1	1	1	
6	3XJ-16324-01	PLATE, CLUTCH 1	7	7	7	7	
7	5DH-16321-00	PLATE, FRICTION	6	6	6	6	
8	5HD-16351-00	PLATE, PRESSURE 1	1	1	1	1	
9	90501-23391	SPRING, COMPRESSION	5	5	5	5	
10	90159-06016	SCREW, WITH WASHER	5	5	5	5	
11	3SB-16356-10	ROD, PUSH 1	1	1	1	1	
12	93340-21008	BEARING	1	1	1	1	
13	3XJ-16321-00	PLATE, FRICTION	2	2	2	2	
14	90201-20611	WASHER, PLATE	1	1	1	1	
15	3XJ-16181-00	SPACER 1	1	1	1	1	
16	93310-225N0	BEARING	1	1	1	1	
17	90201-20611	WASHER, PLATE	1	1	1	1	
18	90215-16289	WASHER, LOCK	1	1	1	1	
19	90170-16326	NUT	1	1	1	1	
20	90508-141B4	SPRING, TORSION	1	1	1	1	
21	4XV-16340-01	PUSH LEVER ASSY	1	1	1	1	
22	90201-08759	WASHER, PLATE	1	1	1	1	
23	93430-08053	CIRCLIP	1	1	1	1	

FIG. 13 TRANSMISSION

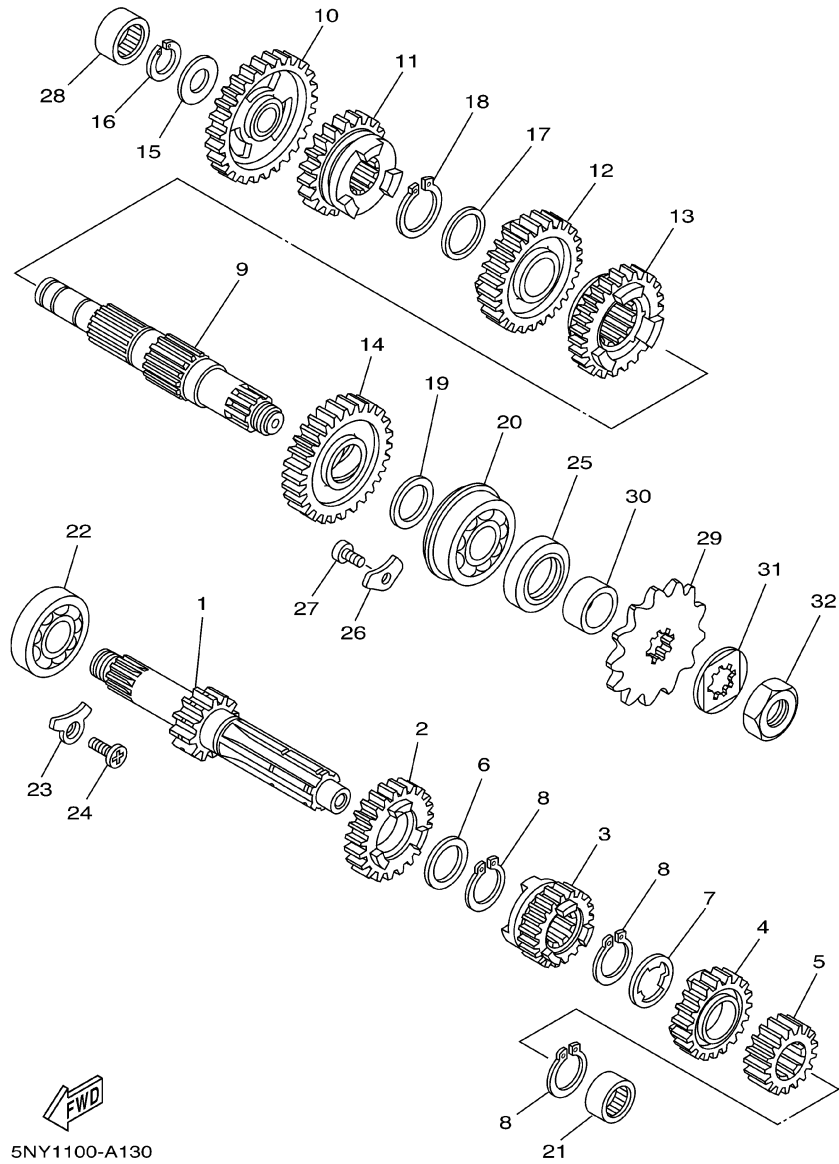

REF. NO.	PART NO.	DESCRIPTION	5NY1	5NY2	5NY3	5NY4	REMARKS
1	5NY-17411-00	AXLE, MAIN	1	1	1	1	
2	5NY-17151-00	GEAR, 5TH PINION (23T)	1	1	1	1	
3	5NY-17131-00	GEAR, 3RD PINION (19T)	1	1	1	1	
4	5NY-17141-00	GEAR, 4TH PINION (19T)	1	1	1	1	
5	5NY-17121-00	GEAR, 2ND PINION (17T)	1	1	1	1	
6	90201-22555	WASHER, PLATE	1	1	1	1	
7	90209-18135	WASHER	1	1	1	1	
8	93410-22039	CIRCLIP	3	3	3	3	
9	5NY-17421-00	AXLE, DRIVE	1	1	1	1	
10	5NY-17211-00	GEAR, 1ST WHEEL (27T)	1	1	1	1	
11	5NY-17251-00	GEAR, 5TH WHEEL (25T)	1	1	1	1	
12	5NY-17231-00	GEAR, 3RD WHEEL (29T)	1	1	1	1	
13	5NY-17241-00	GEAR, 4TH WHEEL (24T)	1	1	1	1	
14	5NY-17221-00	GEAR, 2ND WHEEL (31T)	1	1	1	1	
15	90201-15700	WASHER, PLATE	1	1	1	1	
16	93440-15012	CIRCLIP	1	1	1	1	
17	90201-22793	WASHER, PLATE	1	1	1	1	
18	93410-22039	CIRCLIP	1	1	1	1	
19	90201-20611	WASHER, PLATE	1	1	1	1	
20	93306-30411	BEARING (B6304)	1	1	1	1	
21	93311-41530	BEARING	1	1	1	1	
22	93306-20431	BEARING (B6204Z)	1	1	1	1	
23	1LX-15383-00	PLATE, BEARING COVER	1	1	1	1	
24	90151-06037	SCREW, COUNTERSUNK	1	1	1	1	
25	93102-26042	OIL SEAL	1	1	1	1	
26	4XM-15383-00	PLATE, BEARING COVER	2	2	2	2	
27	90151-06037	SCREW, COUNTERSUNK	2	2	2	2	

FIG. 13 TRANSMISSION

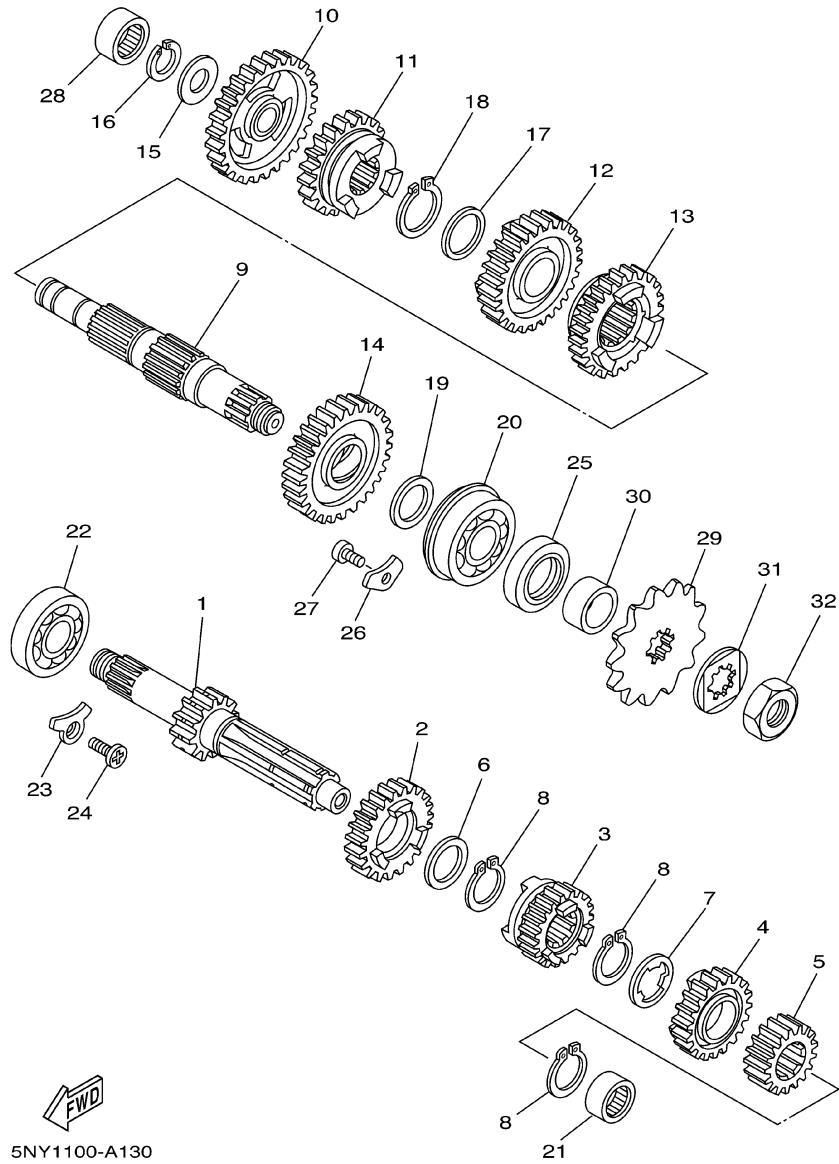

REF. NO.	PART NO.	DESCRIPTION	5NY1	5NY2	5NY3	5NY4	REMARKS
28	93311-31515	BEARING	1	1	1	1	
29	9383A-13031	SPROCKET,DRIVE (13T) (2HG1746130)	1	1	1	1	STD
	9383A-12017	SPROCKET,DRIVE (12T) (2HG1746120)	1	1	1	1	AP
	9383A-14054	SPROCKET,DRIVE (14T) (2HG1746140)	1	1	1	1	AP
30	90387-202A0	COLLAR	1	1	1	1	
31	90215-20261	WASHER, LOCK	1	1	1	1	
32	90179-16226	NUT	1	1	1	1	

FIG. 14 SHIFT CAM. FORK

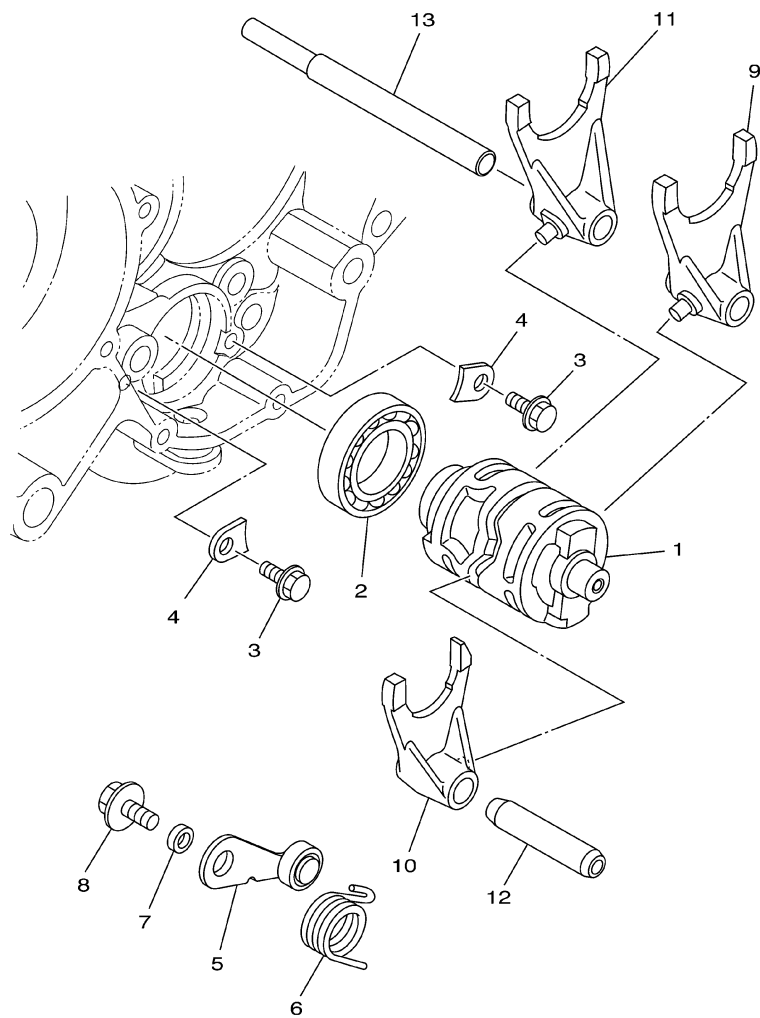

5NY1100-A140

REF. NO.	PART NO.	DESCRIPTION	5NY1	5NY2	5NY3	5NY4	REMARKS
1	5NY-18541-00	CAM, SHIFT	1	1	1	1	
2	93306-90504	BEARING	1	1	1	1	
3	90105-06553	BOLT, FLANGE	2	2	2	2	
4	5DH-18562-00	PLATE, STOPPER 2	2	2	2	2	
5	5HD-18140-00	STOPPER LEVER ASSY	1	1	1	1	
6	90508-261B7	SPRING, TORSION	1	1	1	1	
7	90387-063F7	COLLAR	1	1	1	1	
8	90159-06078	SCREW, WITH WASHER	1	1	1	1	
9	5NY-18511-00	FORK, SHIFT 1	1	1	1	1	
10	5NY-18512-00	FORK, SHIFT 2	1	1	1	1	
11	5NY-18513-00	FORK, SHIFT 3	1	1	1	1	
12	4EX-18531-00	BAR, SHIFT FORK GUIDE 1	1	1	1	1	
13	4EX-18535-00	BAR, SHIFT FORK GUIDE 2	1	1	1	1	

FIG. 15 SHIFT SHAFT

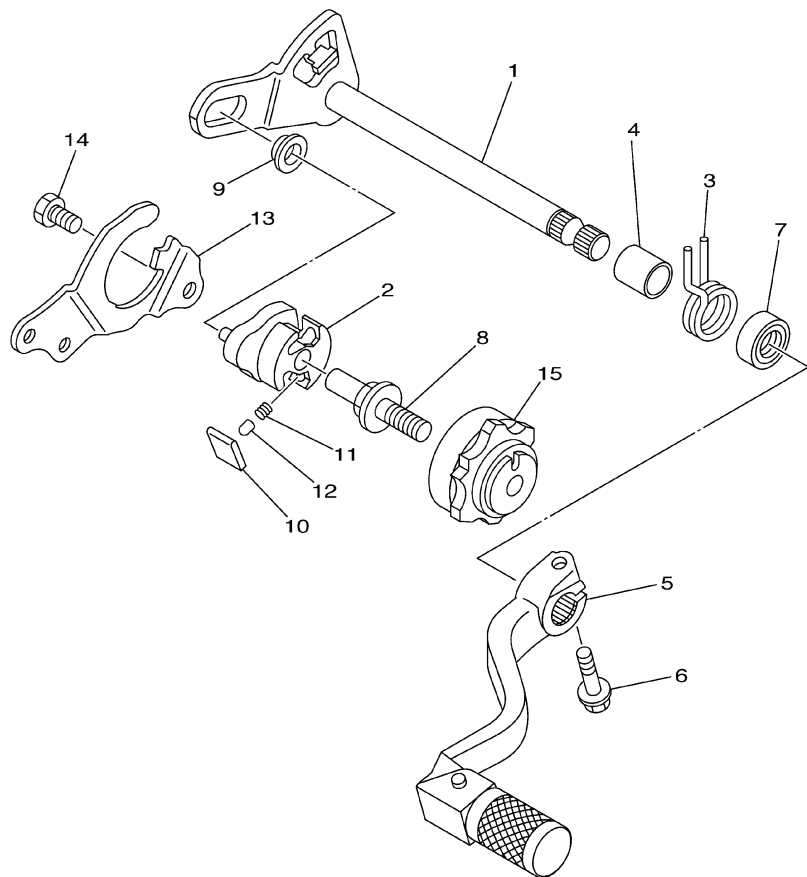

REF. NO.	PART NO.	DESCRIPTION	5NY1	5NY2	5NY3	5NY4	REMARKS
1	4SS-18101-10	SHIFT SHAFT ASSY	1	1	1	1	
2	5MV-18122-00	LEVER, SHIFT 2	1	1	1	1	
3	90508-295A7	SPRING, TORSION	1	1	1	1	
4	90560-12280	SPACER	1	1	1	1	
5	4SS-18110-00	SHIFT PEDAL ASSY	1	1	1	1	
6	95027-06020	BOLT, FLANGE	1	1	1	1	
7	93109-12012	OIL SEAL	1	1	1	1	
8	3XJ-18173-00	PIN, SHIFT	1	1	1	1	
9	3XJ-18178-00	ROLLER, SHIFT LEVER	1	1	1	1	
10	3XJ-18182-00	PAWL, SHIFTER	2	2	2	2	
11	90501-052G5	SPRING, COMPRESSION	2	2	2	2	
12	3XJ-18184-00	PIN, PAWL	2	2	2	2	
13	4JY-18172-00	GUIDE, SHIFT	1	1	1	1	
14	90101-06664	BOLT	2	2	2	2	
15	4EW-18185-00	SEGMENT	1	1	1	1	



5MV1100-1150

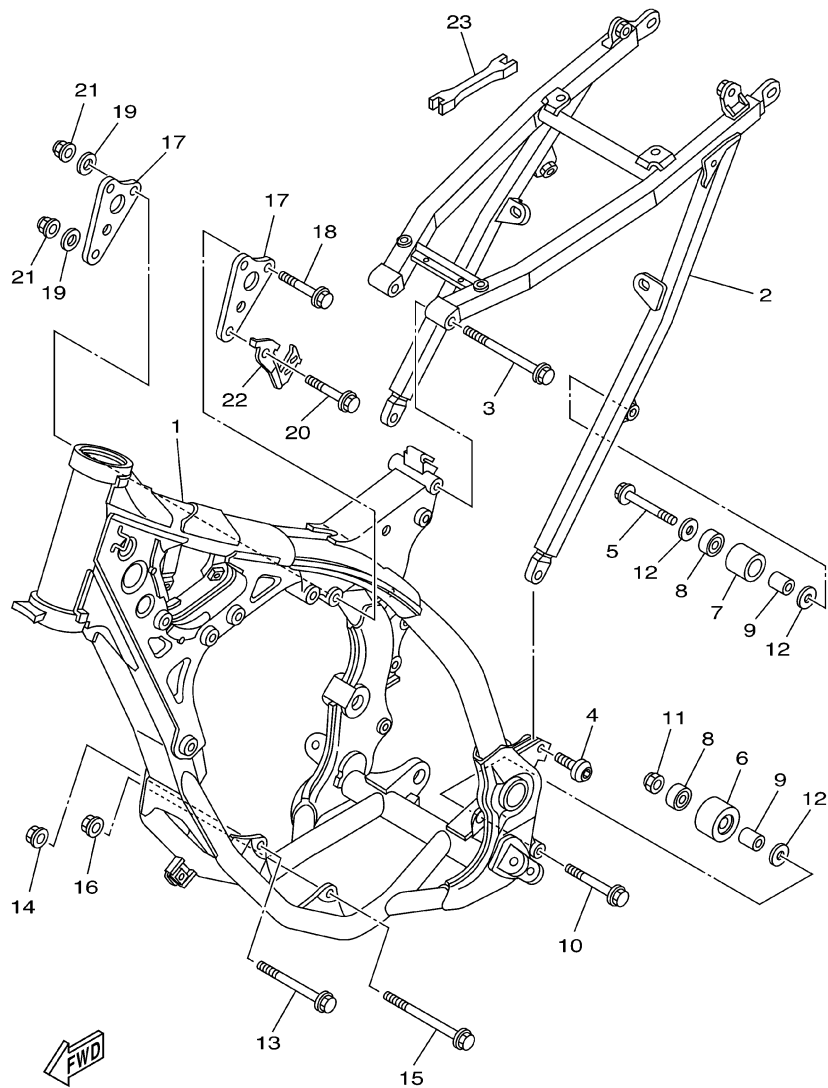
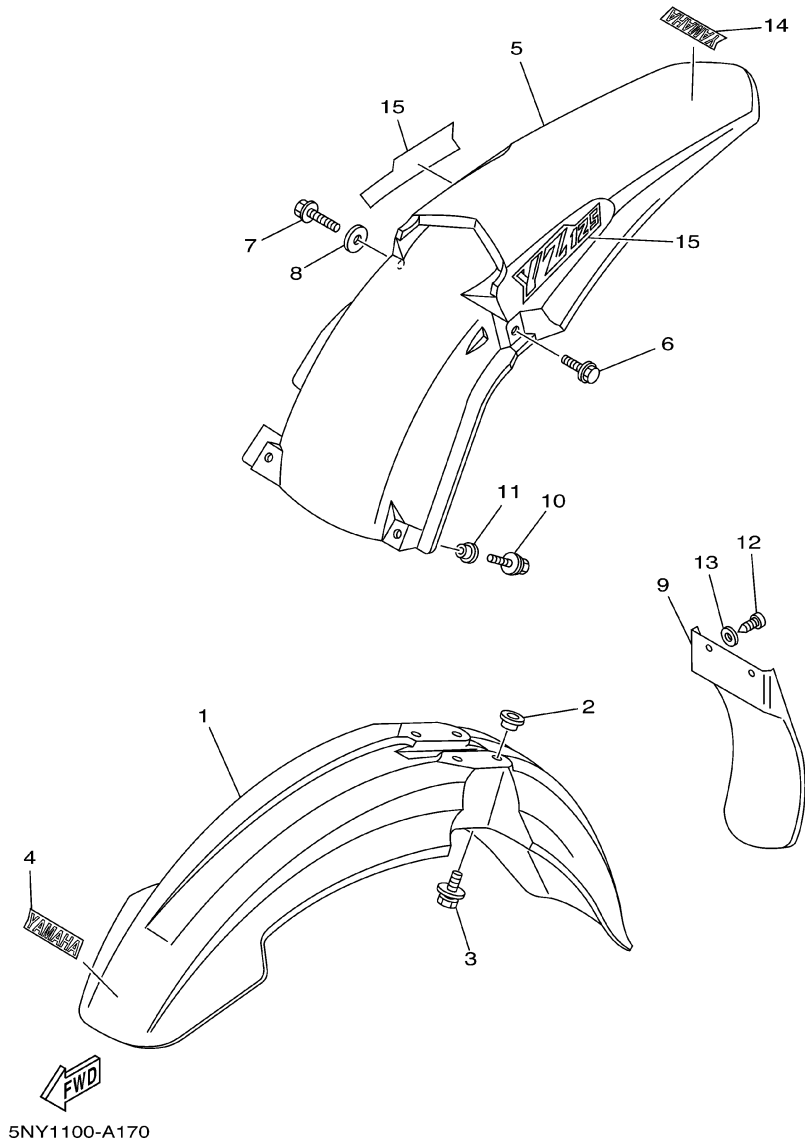

FIG. 16 FRAME

REF. NO.	PART NO.	DESCRIPTION	5NY1	5NY2	5NY3	5NY4	REMARKS
1	5NY-21101-00	FRONT FRAME COMP.	1	1	1	1	
2	5NY-21190-00	REAR FRAME COMP.	1	1	1	1	
3	90105-08120	BOLT, FLANGE	1	1	1	1	
4	90110-08096	BOLT, HEXAGON SOCKET HEAD	2	2	2	2	
5	95027-08040	BOLT, FLANGE	1	1	1	1	
6	3JD-22178-10	TENSIONER	1	1	1	1	
7	4EW-22178-00	TENSIONER	1	1	1	1	
8	93300-60804	BEARING	2	2	2	2	
9	90387-086N4	COLLAR	2	2	2	2	
10	95027-08055	BOLT, FLANGE	1	1	1	1	
11	90185-08055	NUT, SELF-LOCKING	1	1	1	1	
12	90201-086P8	WASHER, PLATE	3	3	3	3	
13	95817-10090	BOLT, FLANGE	1	1	1	1	
14	95607-10200	NUT, SELF-LOCKING	1	1	1	1	
15	90105-10733	BOLT, FLANGE	1	1	1	1	
16	95607-10200	NUT, SELF-LOCKING	1	1	1	1	
17	5NY-21425-00	BRACKET, REAR UPPER 1	2	2	2	2	
18	95817-08050	BOLT, FLANGE	2	2	2	2	
19	90201-08730	WASHER, PLATE	3	3	3	3	
20	90105-08494	BOLT, FLANGE	1	1	1	1	
21	90185-08169	NUT, SELF-LOCKING	3	3	3	3	
22	5NY-21274-00	BRACKET, C.D.I. UNIT	1	1	1	1	
23	5ET-28166-00	WRENCH, HEXAGON	1	1	1	1	

FIG. 17 FENDER



REF. NO.	PART NO.	DESCRIPTION	5NY1	5NY2	5NY3	5NY4	REMARKS
1	5HD-21511-00	FENDER, FRONT	1	1	1	1	
2	3JD-21748-00	COLLAR	4	4	4	4	
3	90119-06096	BOLT, WITH WASHER	4	4	4	4	
4	4ES-2153E-01	EMBLEM, YAMAHA	1	1	1	1	
5	5NY-21610-00	REAR FENDER COMP.	1	1	1	1	
6	90119-06192	BOLT, WITH WASHER	1	1	1	1	
7	95027-06030	BOLT, FLANGE	1	1	1	1	
8	90201-06071	WASHER, PLATE	1	1	1	1	
9	5BE-21642-00	GUARD, FLAP	1	1	1	1	
10	90119-06225	BOLT, WITH WASHER	2	2	2	2	
11	90387-06009	COLLAR	2	2	2	2	
12	97707-60016	SCREW, TAPPING	2	2	2	2	
13	90201-06557	WASHER, PLATE	2	2	2	2	
14	4ES-2153E-01	EMBLEM, YAMAHA	1	1	1	1	
15	5NY-2163G-00	EMBLEM 1	2	2	2	2	

FIG. 18 SIDE COVER

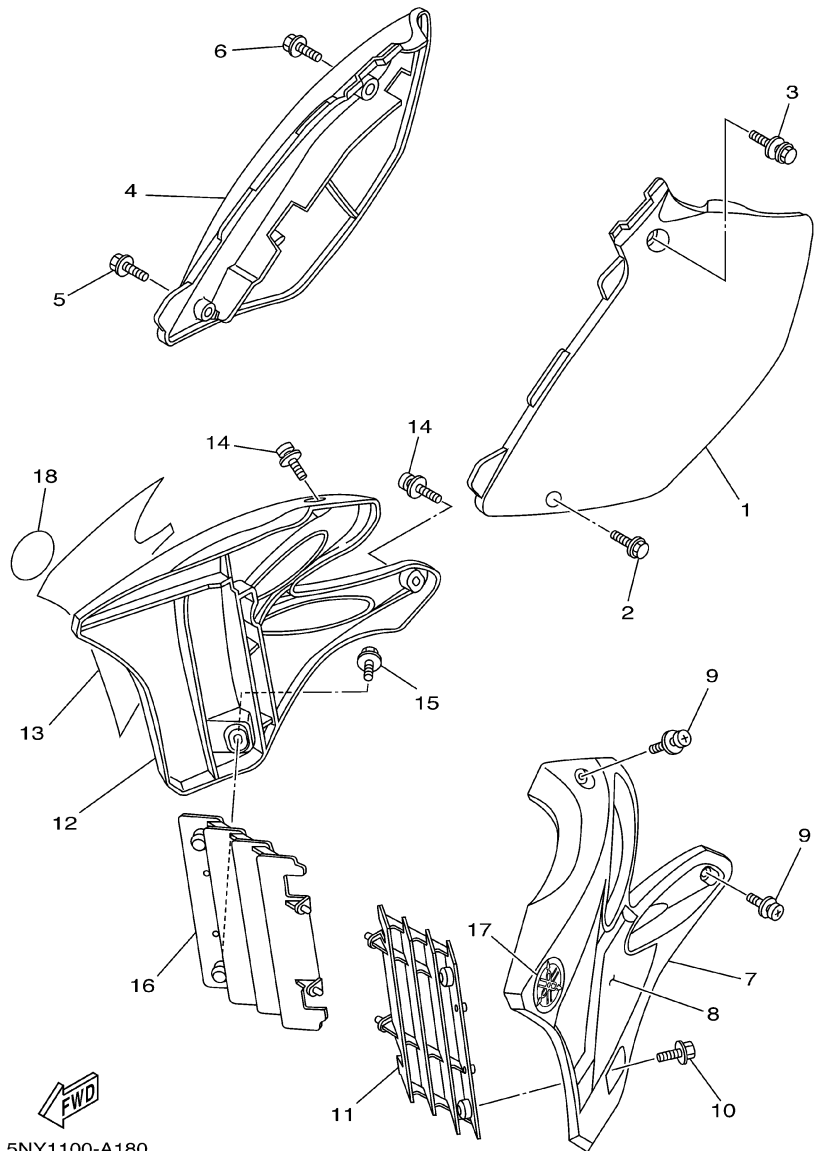

5NY1100-A180

REF. NO.	PART NO.	DESCRIPTION	5NY1	5NY2	5NY3	5NY4	REMARKS
1	5NY-21711-00	COVER, SIDE 1	1	1	1	1	
2	95827-06016	BOLT, FLANGE	1	1	1	1	
3	90119-08238	BOLT, WITH WASHER	1	1	1	1	
4	5NY-21721-00	COVER, SIDE 2	1	1	1	1	
5	95827-06016	BOLT, FLANGE	1	1	1	1	
6	90119-08238	BOLT, WITH WASHER	1	1	1	1	
7	5NY-21730-00	SIDE COVER ASSY 3	1	1	1	1	
8	5NY-2173E-01	GRAPHIC 1	1	1	1	1	
9	90159-06182	SCREW, WITH WASHER	2	2	2	2	
10	90159-06078	SCREW, WITH WASHER	1	1	1	1	
11	5NL-2172A-10	PANEL 1	1	1	1	1	
12	5NY-21740-00	SIDE COVER ASSY 4	1	1	1	1	
13	5NY-2173F-01	GRAPHIC 2	1	1	1	1	
14	90159-06182	SCREW, WITH WASHER	2	2	2	2	
15	90159-06078	SCREW, WITH WASHER	1	1	1	1	
16	5NL-2172A-10	PANEL 1	1	1	1	1	
17	5MV-2175C-00	TUNING FORK MARK	1	1	1	1	
18	5MV-2175C-00	TUNING FORK MARK	1	1	1	1	

FIG. 19 REAR ARM

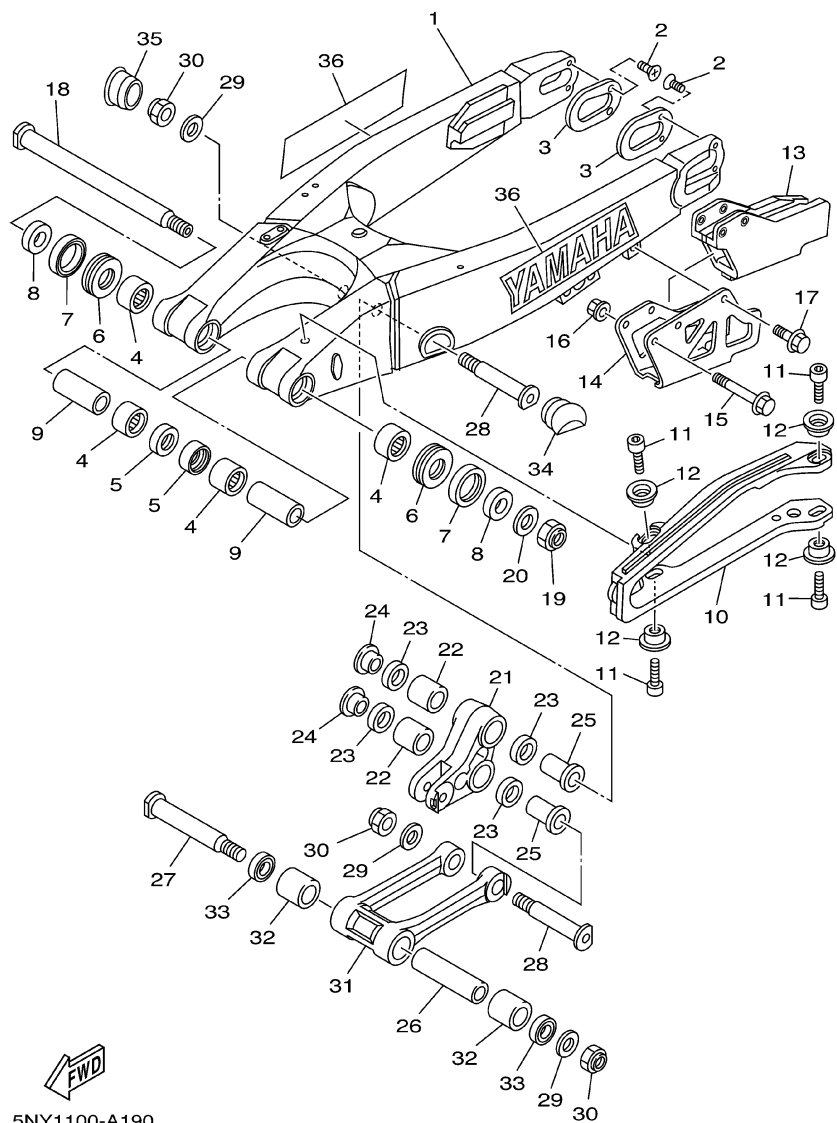

REF. NO.	PART NO.	DESCRIPTION	5NY1	5NY2	5NY3	5NY4	REMARKS
1	5NY-22110-00	REAR ARM COMP.	1	1	1	1	
2	90151-04048	SCREW, COUNTERSUNK	4	4	4	4	
3	5NY-22355-00	PATCH	2	2	2	2	
4	93317-22262	BEARING	4	4	4	4	
5	93106-22019	OIL SEAL (DC 22-28-8)	2	2	2	2	
6	93342-22217	BEARING	2	2	2	2	
7	93109-28043	OIL SEAL	2	2	2	2	
8	90387-18005	COLLAR	2	2	2	2	
9	90387-18004	COLLAR	2	2	2	2	
10	5MV-22151-00	SEAL, GUARD	1	1	1	1	
11	91317-05008	BOLT	4	4	4	4	
12	5JG-22156-00	WASHER, PLATE	4	4	4	4	
13	4XM-22199-00	SUPPORT, CHAIN	1	1	1	1	
14	4XM-22128-00	COVER, THRUST 1	1	1	1	1	
15	95027-06050	BOLT, FLANGE	2	2	2	2	
16	90179-06568	NUT	2	2	2	2	
17	95027-06010	BOLT, FLANGE	1	1	1	1	
18	5NY-22141-00	SHAFT, PIVOT	1	1	1	1	
19	90185-16127	NUT, SELF-LOCKING	1	1	1	1	
20	90201-160F6	WASHER, PLATE	1	1	1	1	
21	5NY-2217A-00	ARM, RELAY	1	1	1	1	
22	93315-32056	BEARING	2	2	2	2	
23	93109-20076	OIL SEAL	4	4	4	4	
24	90387-16005	COLLAR	2	2	2	2	
25	90387-16007	COLLAR	2	2	2	2	
26	90387-167Y9	COLLAR	1	1	1	1	
27	5NY-22121-00	SHAFT 1	1	1	1	1	

FIG. 19 REAR ARM

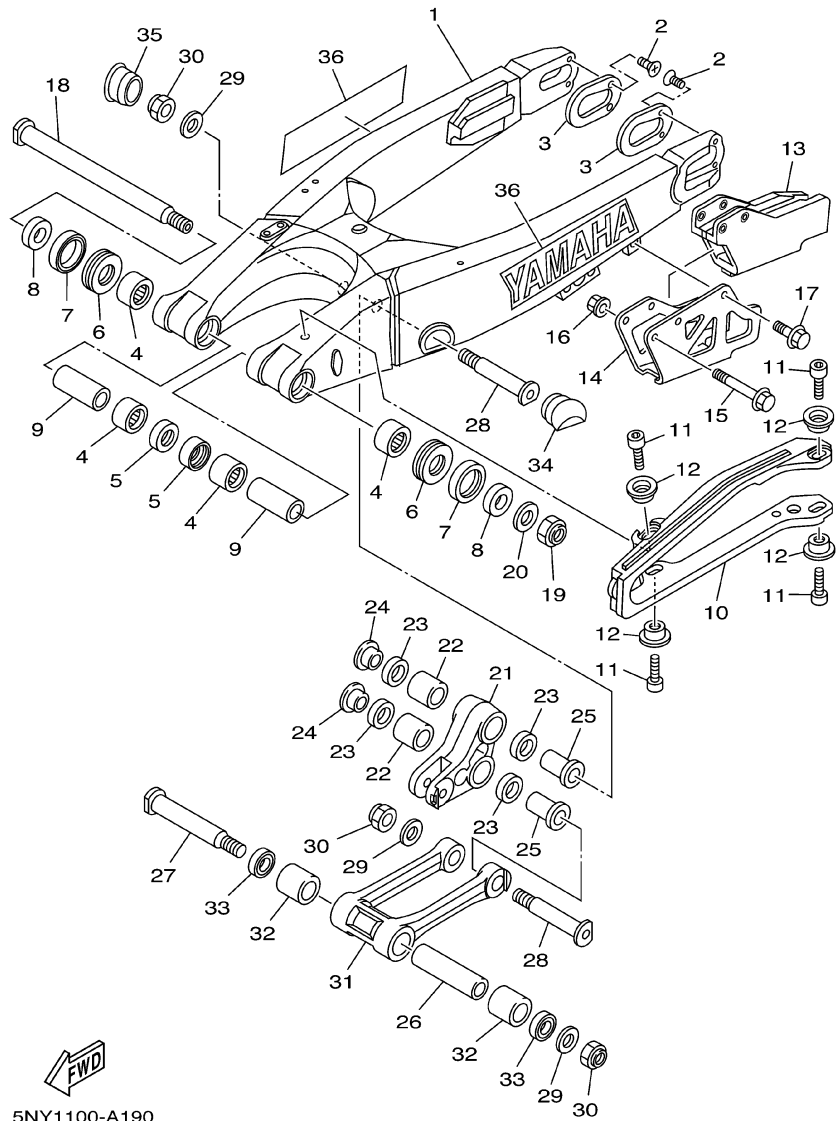

5NY1100-A190

REF. NO.	PART NO.	DESCRIPTION	5NY1	5NY2	5NY3	5NY4	REMARKS
28	5NY-22122-00	SHAFT 2	2	2	2	2	
29	90201-14740	WASHER, PLATE	3	3	3	3	
30	90185-14007	NUT, SELF-LOCKING	3	3	3	3	
31	5NY-2217F-00	ROD, CONNECTING 1	1	1	1	1	
32	93315-32053	BEARING	2	2	2	2	
33	93109-20076	OIL SEAL	2	2	2	2	
34	5NY-2135F-00	COVER	1	1	1	1	
35	5HD-2135F-00	COVER	1	1	1	1	
36	99244-00200	EMBLEM, YAMAHA	2	2	2	2	

FIG. 20 REAR SUSPENSION

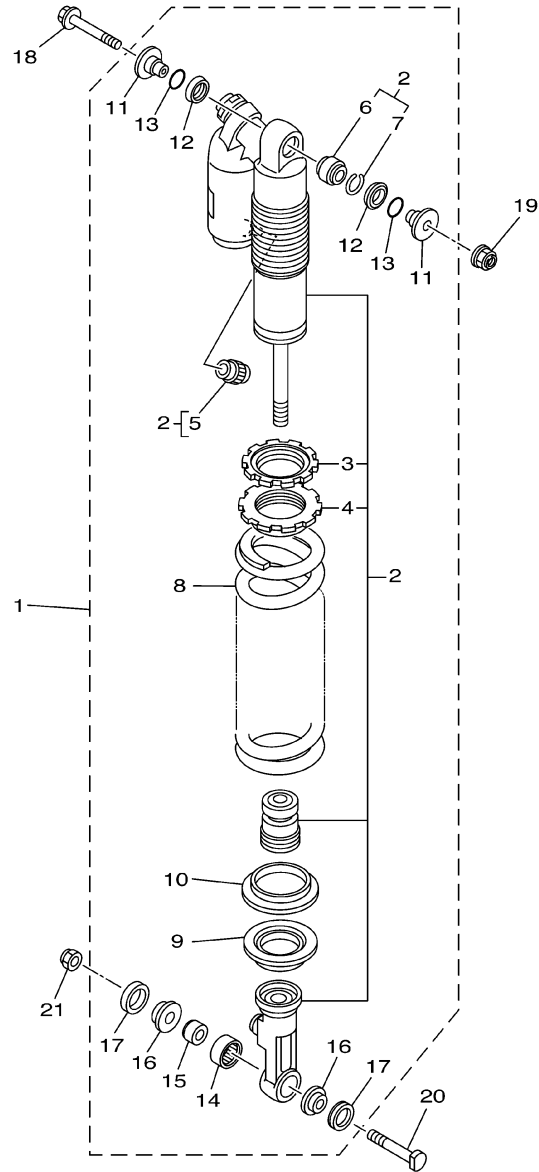

5NY1100-A200

REF. NO.	PART NO.	DESCRIPTION					REMARKS
			5NY1	5NY2	5NY3	5NY4	
1	5NY-22210-40	SHOCK ABSORBER ASSY, REAR1	1				UR FOR ZAF
2	5NY-22201-40	.DAMPER SUB ASSY	1				UR FOR ZAF
3	3SP-22234-00	..GUIDE, SPRING 3	1	1	1	1	
4	3SP-22213-00	..SEAT, SPRING UPPER	1	1	1	1	
5	509-23184-L0	..CAP, AIR VALVE	1	1	1	1	
6	4JX-22226-00	..BUSH, SHOCK ABSORBER LOWER	1	1	1	1	
7	5DH-23183-00	..CIRCLIP	1	1	1	1	
8	5DH-22212-10	..SPRING (K=4.6)	1		1	1	
9	5DH-22214-00	..GUIDE, SPRING 1	1	1	1	1	
10	5MV-22224-00	..GUIDE, SPRING 2	1	1	1	1	
11	5DH-22253-00	..COLLAR, DISTANCE	2	2	2	2	
12	3JE-22475-00	..SEAL, DUST	2	2	2	2	
13	4EW-22474-00	..SEAL, RING	2	2	2	2	
14	5MV-22176-00	..BEARING	1	1	1	1	
15	5MV-22184-00	..BUSH	1	1	1	1	
16	5MV-22253-00	..COLLAR, DISTANCE	2	2	2	2	
17	5NY-22475-00	..SEAL, DUST	2	2	2	2	
18	90105-10323	BOLT, FLANGE	1	1	1	1	

FIG. 20 REAR SUSPENSION

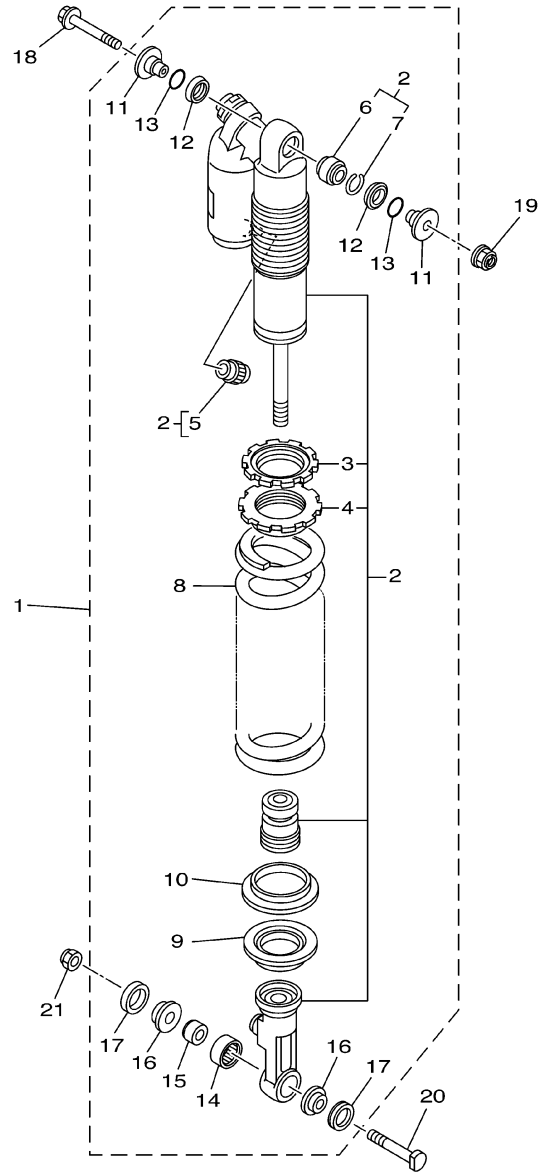

5NY1100-A200

REF. NO.	PART NO.	DESCRIPTION	5NY1	5NY2	5NY3	5NY4	REMARKS
19	95607-10200	NUT, SELF-LOCKING	1	1	1	1	
20	5NY-22241-00	BOLT 1	1	1	1	1	
21	90185-10060	NUT, SELF-LOCKING	1	1	1	1	

FIG. 21 STEERING

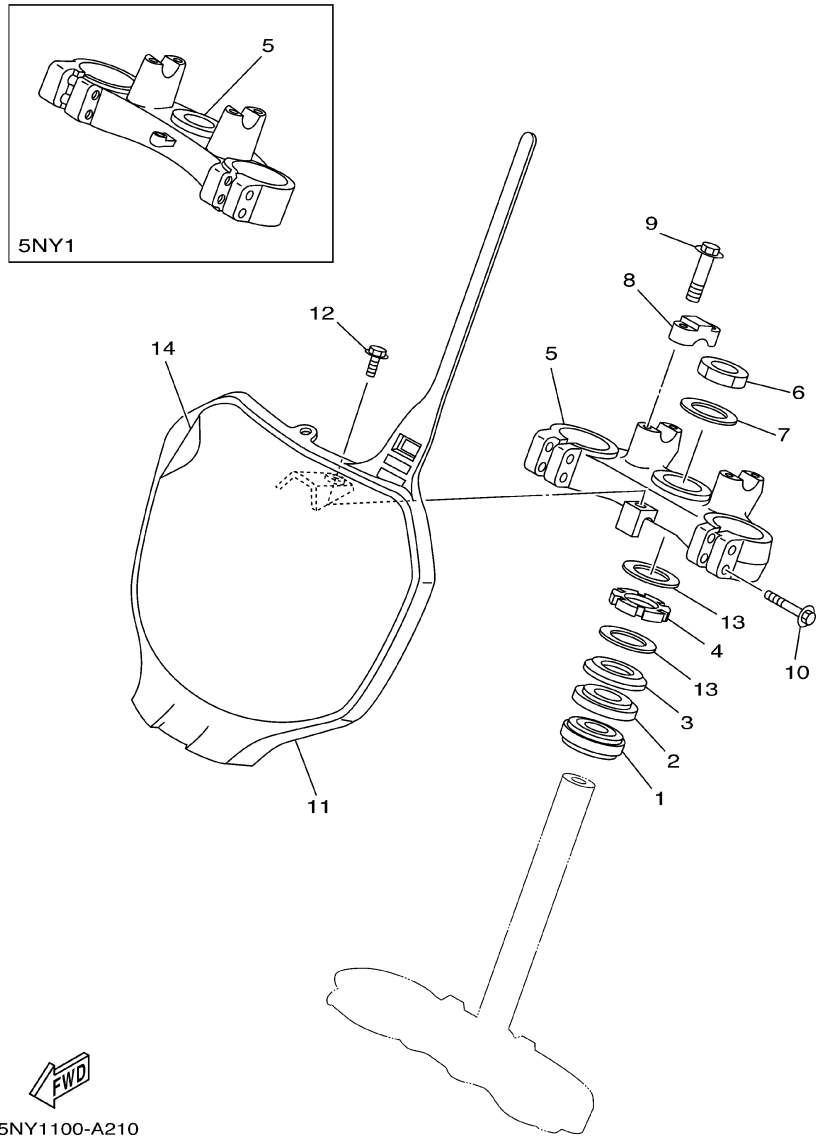

REF. NO.	PART NO.	DESCRIPTION	5NY1	5NY2	5NY3	5NY4	REMARKS
1	93332-00081	BEARING	1	1	1	1	
2	93332-00068	BEARING	1	1	1	1	
3	4EW-23416-00	COVER, BALL RACE 2	1	1	1	1	
4	90179-28650	NUT	1	1	1	1	
5	5NL-23435-00	CROWN, HANDLE	1				
6	90170-24373	NUT	1	1	1	1	
7	90201-247L2	WASHER, PLATE	1	1	1	1	
8	3SP-23441-00	HOLDER, HANDLE UPPER	2	2	2	2	
9	95027-08035	BOLT, FLANGE	4	4	4	4	
10	95027-08040	BOLT, FLANGE	4	4	4	4	
11	5HD-23485-10	PLATE, NUMBER	1	1	1	1	
12	90119-06225	BOLT, WITH WASHER	1	1	1	1	
13	90201-286K9	WASHER, PLATE	2	2	2	2	
14	5HD-2339E-00	GRAPHIC 1	1	1	1	1	



5NY1100-A210

FIG. 22 FRONT FORK

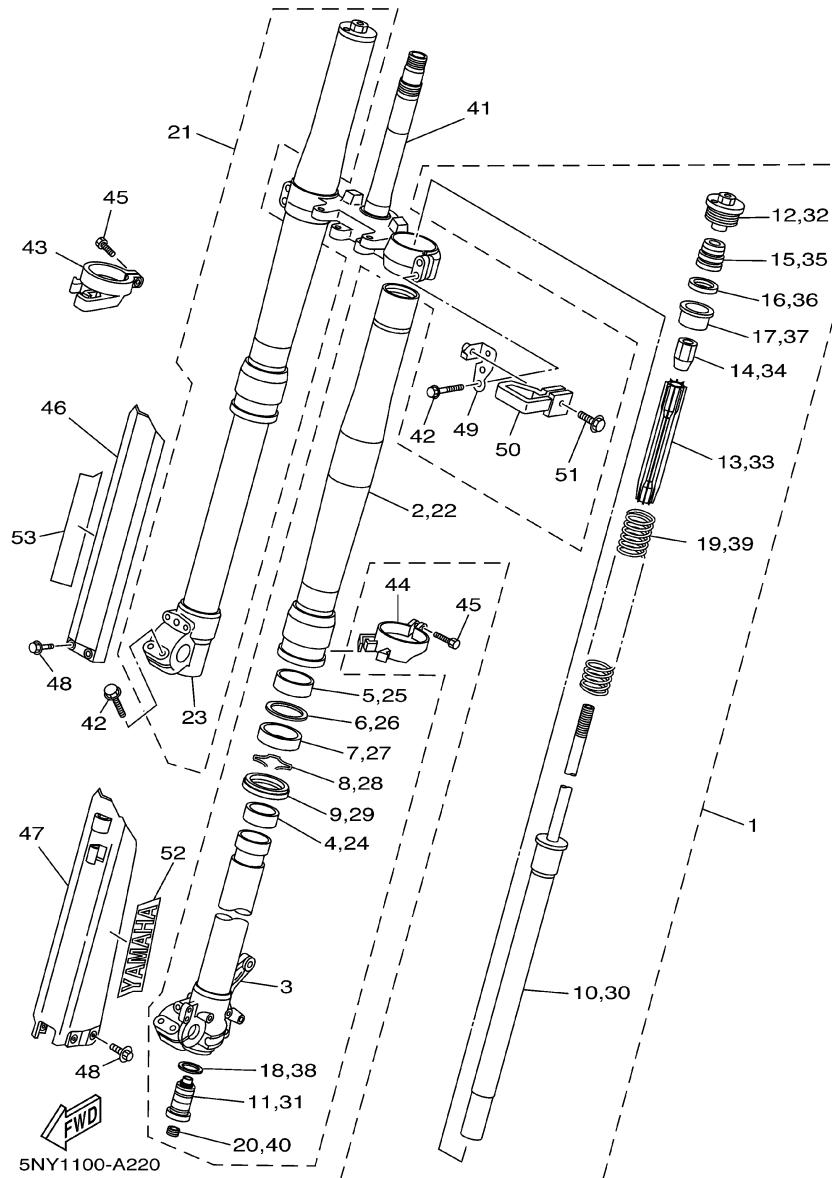

REF. NO.	PART NO.	DESCRIPTION	5NY1	5NY2	5NY3	5NY4	REMARKS
1	5NY-23102-00	FRONT FORK ASSY (L.H)	1			1	
2	5HD-23136-L0	.TUBE, OUTER (RIGHT)	1	1	1	1	
3	5DH-23120-L0	.INNER TUBE COMP.2	1	1	1	1	
4	5ET-23171-L0	.PISTON, FRONT FORK	1	1	1	1	
5	5ET-23125-L0	.METAL, SLIDE 1	1	1	1	1	
6	4SS-23146-L0	.WASHER, OIL SEAL	1	1	1	1	
7	5ET-23145-L0	.OIL SEAL	1	1	1	1	
8	4SS-23153-L0	.RING, SNAP	1	1	1	1	
9	5HD-23144-L0	.SEAL, DUST	1	1	1	1	
10	5NY-23170-L0	.CYLINDER COMP., FRONT FORK	1		1	1	
11	5NY-2316A-L0	.VALVE COMP.	1		1	1	
12	5NY-23111-L0	.BOLT, CAP	1	1	1	1	
13	5DH-23142-L0	.SEAT, SPRING UPPER	1	1	1	1	
14	5HD-23393-L0	.NUT, SPECIAL	1	1	1	1	
15	5MV-23195-L0	.RUBBER	1			1	
16	5DH-23149-L0	.WASHER, SPRING UPPER	1	1	1	1	
17	5DH-23118-L0	.SPACER	1	1	1	1	
18	4SS-23158-L0	.GASKET	1	1	1	1	
19	4XM-23141-L0	.SPRING, FRONT FORK (K=0.41)	1		1	1	
20	3JD-2312G-L0	.PLUG	1	1	1	1	
21	5NY-23103-00	FRONT FORK ASSY (R.H)	1			1	

FIG. 22 FRONT FORK

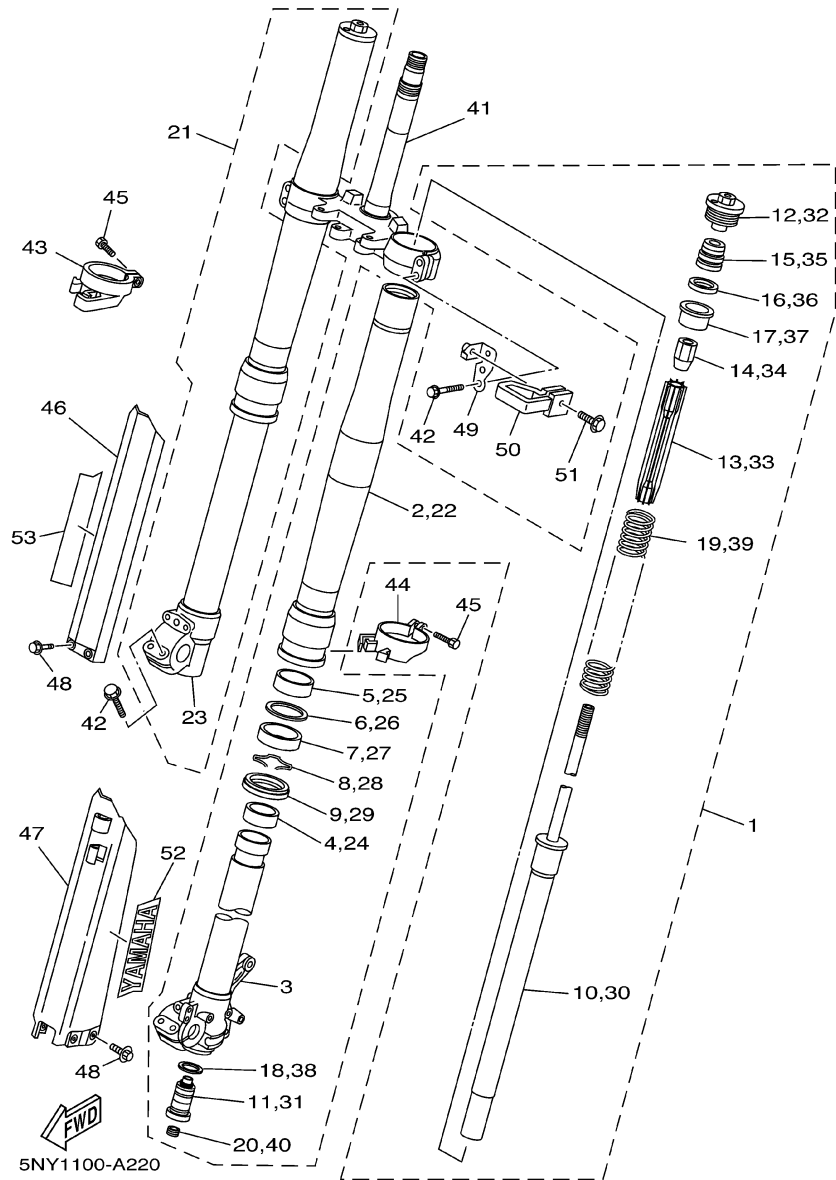

REF. NO.	PART NO.	DESCRIPTION	5NY1	5NY2	5NY3	5NY4	REMARKS
22	5HD-23136-L0	.TUBE, OUTER (RIGHT)	1	1	1	1	
23	5BF-23110-L0	.INNER TUBE COMP.1	1	1	1	1	
24	5ET-23171-L0	.PISTON, FRONT FORK	1	1	1	1	
25	5ET-23125-L0	.METAL, SLIDE 1	1	1	1	1	
26	4SS-23146-L0	.WASHER, OIL SEAL	1	1	1	1	
27	5ET-23145-L0	.OIL SEAL	1	1	1	1	
28	4SS-23153-L0	.RING, SNAP	1	1	1	1	
29	5HD-23144-L0	.SEAL, DUST	1	1	1	1	
30	5NY-23170-L0	.CYLINDER COMP., FRONT FORK	1		1	1	
31	5NY-2316A-L0	.VALVE COMP.	1		1	1	
32	5NY-23111-L0	.BOLT, CAP	1	1	1	1	
33	5DH-23142-L0	.SEAT, SPRING UPPER	1	1	1	1	
34	5HD-23393-L0	.NUT, SPECIAL	1	1	1	1	
35	5MV-23195-L0	.RUBBER	1				
36	5DH-23149-L0	.WASHER, SPRING UPPER	1	1	1	1	
37	5DH-23118-L0	.SPACER	1	1	1	1	
38	4SS-23158-L0	.GASKET	1	1	1	1	
39	4XM-23141-L0	.SPRING, FRONT FORK (K=0.41)	1		1	1	
40	3JD-2312G-L0	.PLUG	1	1	1	1	
41	5DH-23340-M0	.UNDER BRACKET COMP.	1	1	1	1	
42	5NY-23346-L0	BOLT 1	8	8	8	8	

FIG. 22 FRONT FORK

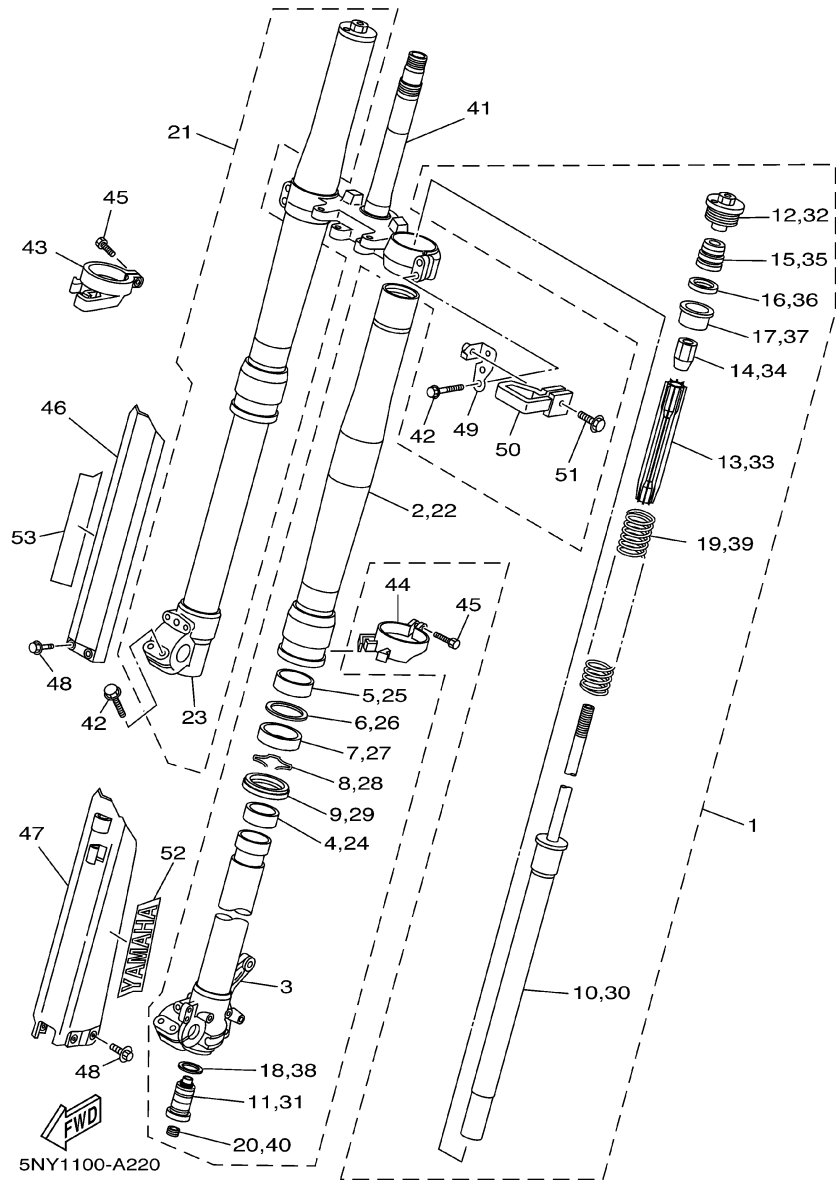

REF. NO.	PART NO.	DESCRIPTION	5NY1	5NY2	5NY3	5NY4	REMARKS
43	4SS-2314G-L0	PROTECTOR GUIDE COMP., 2	1	1	1	1	
44	5DH-2314F-L0	PROTECTOR GUIDE COMP., 1	1	1	1	1	
45	4SS-23346-L0	BOLT 1	2	2	2	2	
46	5DH-2314J-00	PROTECTOR COMP., 2	1	1	1	1	
47	5DH-2314H-00	PROTECTOR COMP., 1	1	1	1	1	
48	3SP-23356-L0	BOLT 2	6	6	6	6	
49	4EW-2331E-L1	GUIDE, CABLE	1	1	1	1	
50	4DA-23389-00	GUIDE, CABLE	1	1	1	1	
51	90119-05071	BOLT, WITH WASHER	1	1	1	1	
52	4XL-2153A-10	EMBLEM, YAMAHA	1	1	1	1	
53	4XL-2153A-10	EMBLEM, YAMAHA	1	1	1	1	

FIG. 23 FUEL TANK

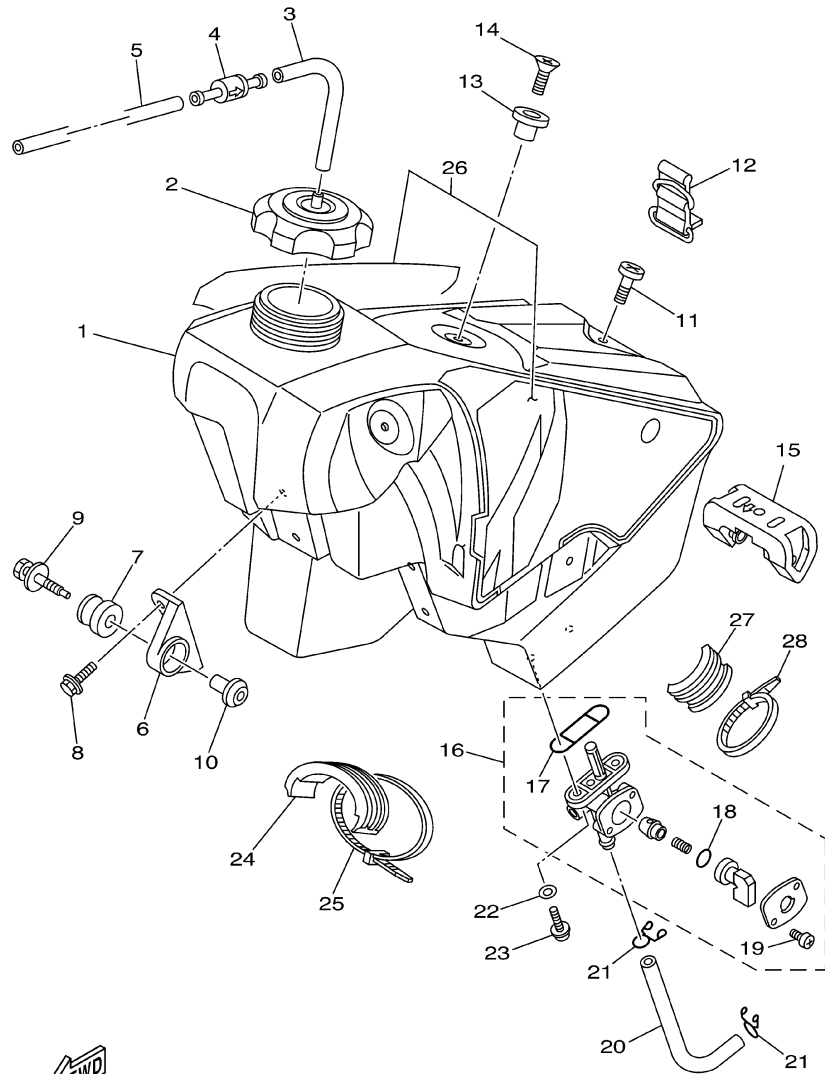

5NY1100-A230

REF. NO.	PART NO.	DESCRIPTION	5NY1	5NY2	5NY3	5NY4	REMARKS
1	5NY-24110-00	FUEL TANK COMP.	1	1	1	1	
2	5NY-24610-00	CAP ASSY	1	1	1	1	
3	90445-09220	HOSE	1	1	1	1	
4	3XJ-24380-00	PIPE JOINT ASSY	1	1	1	1	
5	90445-09104	HOSE	1	1	1	1	
6	24X-24144-00	HOLDER, DAMPER	2	2	2	2	
7	90480-18549	GROMMET	2	2	2	2	
8	95027-06016	BOLT, FLANGE	4	4	4	4	
9	90119-06214	BOLT, WITH WASHER	2	2	2	2	
10	5NY-24186-00	WASHER, SPECIAL	2	2	2	2	
11	98907-06025	SCREW, BIND	1	1	1	1	
12	3SP-24173-00	BAND, TANK FITTING 1	1	1	1	1	
13	4EW-2412F-00	BRACKET, SEAT	1	1	1	1	
14	98707-06025	SCREW, FLAT HEAD	1	1	1	1	
15	4SS-24181-00	DAMPER, LOCATING 1	1	1	1	1	
16	3JD-24500-01	FUEL COCK ASSY 1	1	1	1	1	
17	4X8-24512-00	.O-RING	1	1	1	1	
18	3AJ-24534-00	.SEAL, COCK	1	1	1	1	
19	97801-03008	.SCREW, PAN HEAD	2	2	2	2	
20	90445-111J0	HOSE (L145)	1	1	1	1	
21	90467-10008	CLIP	2	2	2	2	
22	90202-05193	WASHER, PLATE	2	2	2	2	
23	90149-06011	SCREW	2	2	2	2	
24	5NY-24182-00	DAMPER, LOCATING 2	2	2	2	2	
25	90465-13275	CLAMP	2	2	2	2	
26	5NY-24240-01	GRAPHIC SET	1	1	1	1	
27	5NY-24183-00	DAMPER, LOCATING 3	2	2	2	2	

FIG. 23 FUEL TANK

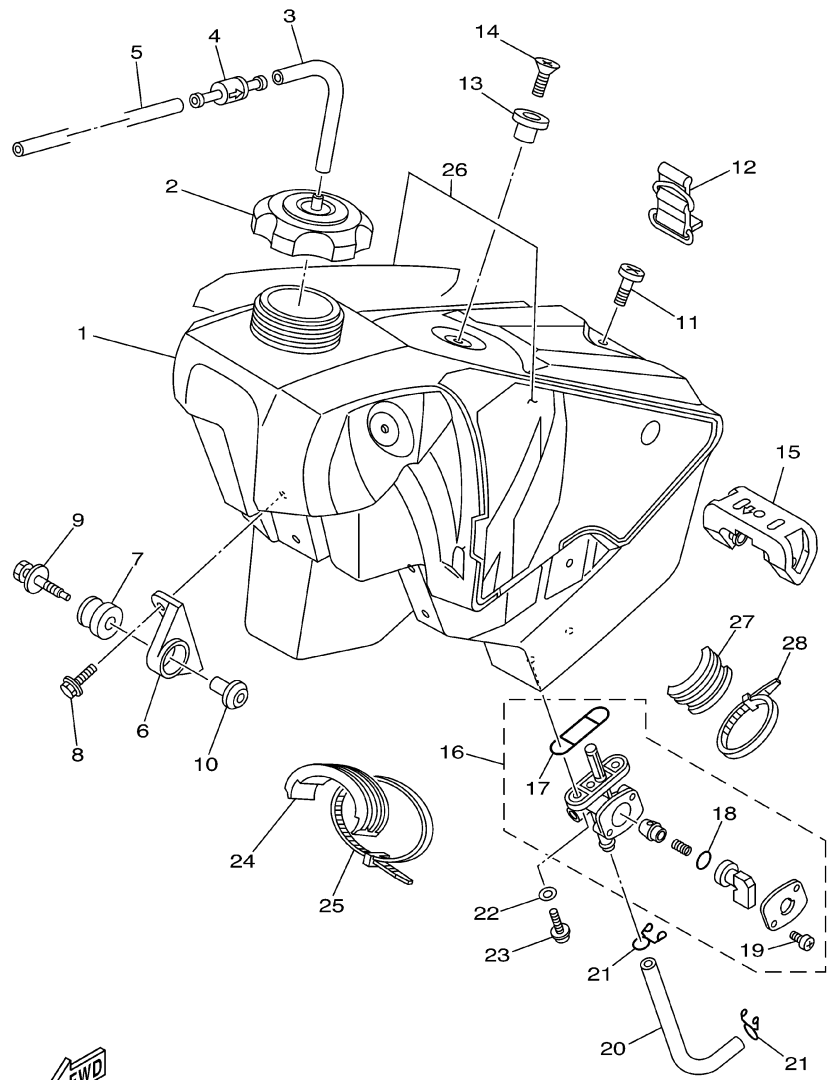

5NY1100-A230

REF. NO.	PART NO.	DESCRIPTION	5NY1	5NY2	5NY3	5NY4	REMARKS
28	90465-13152	CLAMP	2	2	2	2	

FIG. 24 SEAT

REF. NO.	PART NO.	DESCRIPTION	5NY1	5NY2	5NY3	5NY4	REMARKS
1	5NY-24770-00	SEMI-DOUBLE SEAT ASSY	1	1	1	1	
2	5NY-2470F-00	.COVER, SEAT	1	1	1	1	
3	5NY-24728-00	.BRACKET, SEAT	2	2	2	2	
4	97307-06012	.BOLT	4	4	4	4	
5	92907-06100	.WASHER, SPRING	4	4	4	4	

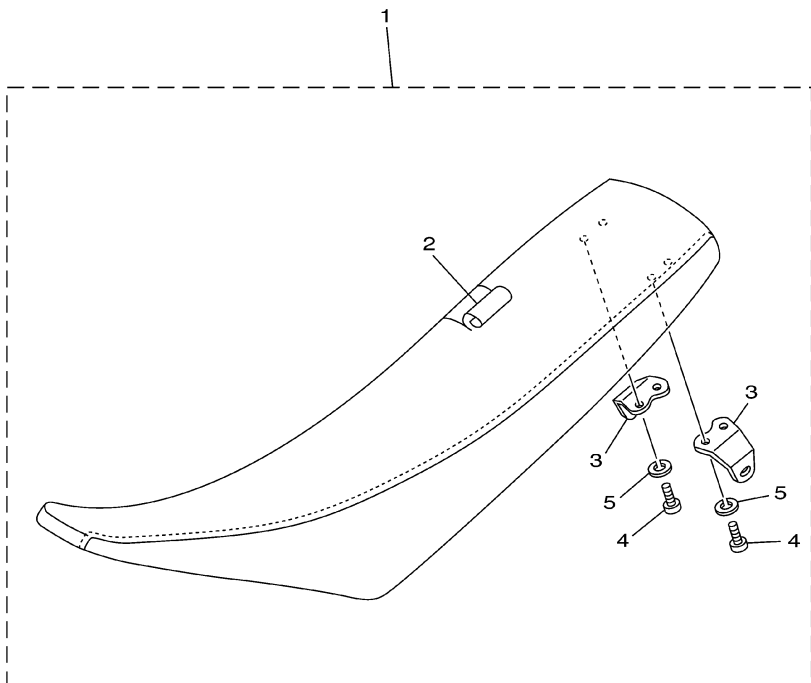

5NY1100-A240

FIG. 25 FRONT WHEEL

REF. NO.	PART NO.	DESCRIPTION	5NY1	5NY2	5NY3	5NY4	REMARKS
1	5NY-25111-00	HUB, FRONT	1	1	1	1	
2	93306-90403	BEARING	2	2	2	2	
3	5NY-25117-00	SPACER, BEARING	1	1	1	1	
4	93102-26468	OIL SEAL	2	2	2	2	
5	94416-21003	RIM (1.60-21)	1	1	1	1	
6	5NY-25104-00	SPOKE SET, FRONT	1	1	1	1	
7		TIRE (80/100-21 51M D739FA)	1				
8		TUBE (80/100-21 TR4 B TL)	1				
9	94309-21161	BAND, RIM (70-80/100-21)	1	1		1	
10	5SF-25394-00	SPACER, BEAD	1	1	1	1	
11	5BE-25181-00	AXLE, WHEEL	1	1	1	1	
12	5NY-25183-00	COLLAR, WHEEL	1	1	1	1	
13	5NY-25186-00	COLLAR, WHEEL	1	1	1	1	
14	90179-16672	NUT	1	1	1	1	

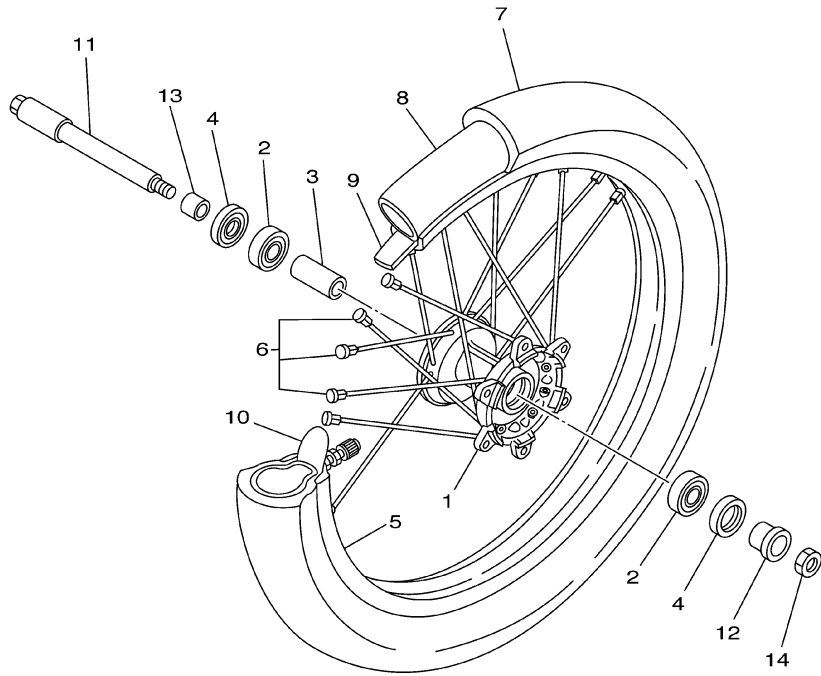

5NY1100-A250

FIG. 26 FRONT BRAKE CALIPER

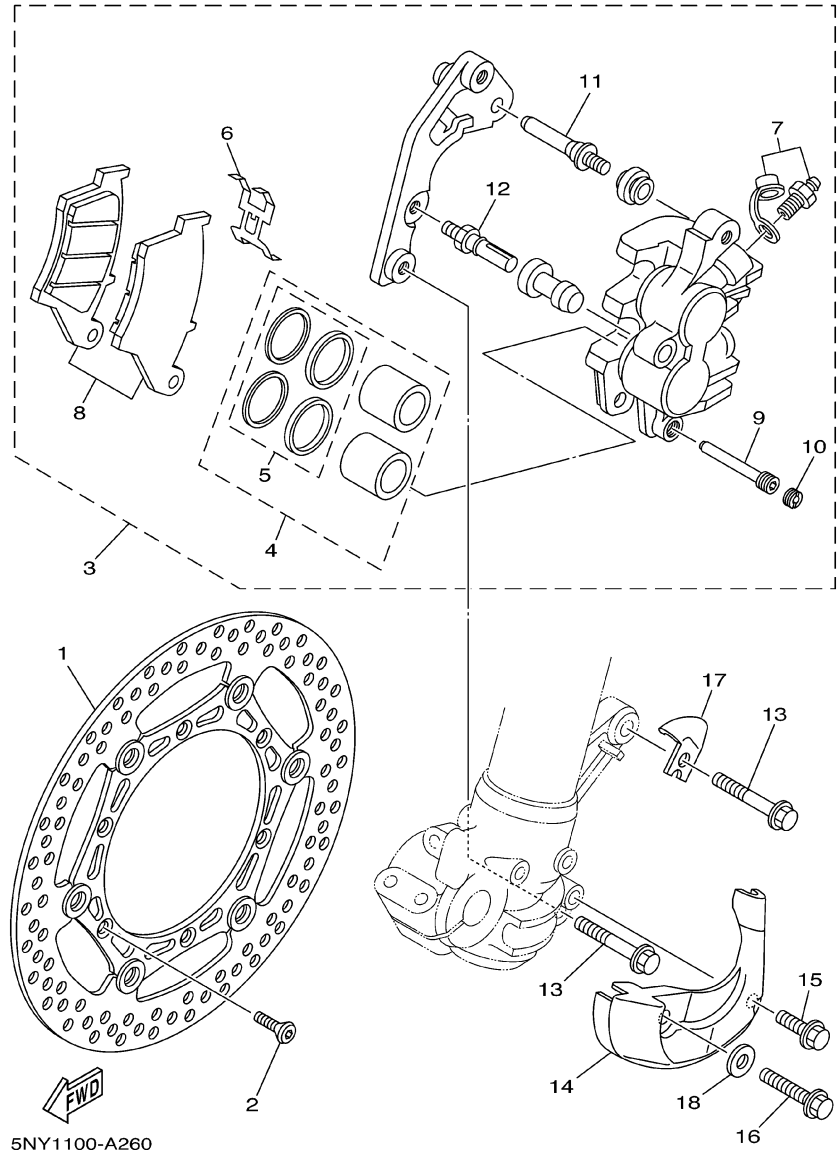

REF. NO.	PART NO.	DESCRIPTION	5NY1	5NY2	5NY3	5NY4	REMARKS
1	5MV-2581T-00	DISC BRAKE ASSY	1	1	1	1	
2	90149-06327	SCREW	6	6	6	6	
3	5MV-2580T-00	CALIPER ASSY (LEFT)	1	1	1	1	
4	4EW-W0057-00	.PISTON ASSY, CALIPER	1	1	1	1	
5	3JD-W0047-00	..CALIPER SEAL KIT	1	1	1	1	
6	5DH-25919-00	.SUPPORT, PAD	1	1	1	1	
7	1UY-W0048-50	.BLEED SCREW KIT	1	1	1	1	
8	5DH-W0045-10	.BRAKE PAD KIT	1	1	1	1	
9	5DH-25933-00	.PIN, PAD	1	1	1	1	
10	5DH-25916-00	.PLUG	1	1	1	1	
11	3SP-25926-51	.BOLT	1	1	1	1	
12	3SP-25914-51	.PIN, SLIDE	1	1	1	1	
13	90105-08659	BOLT, FLANGE	2	2	2	2	
14	5DH-2314E-00	COVER, HOSE	1	1	1	1	
15	95827-06012	BOLT, FLANGE	1	1	1	1	
16	95027-08020	BOLT, FLANGE	1	1	1	1	
17	5DH-25875-00	HOLDER, BRAKE HOSE 1	1	1	1	1	
18	92907-08200	WASHER	1	1	1	1	

FIG. 27 REAR WHEEL

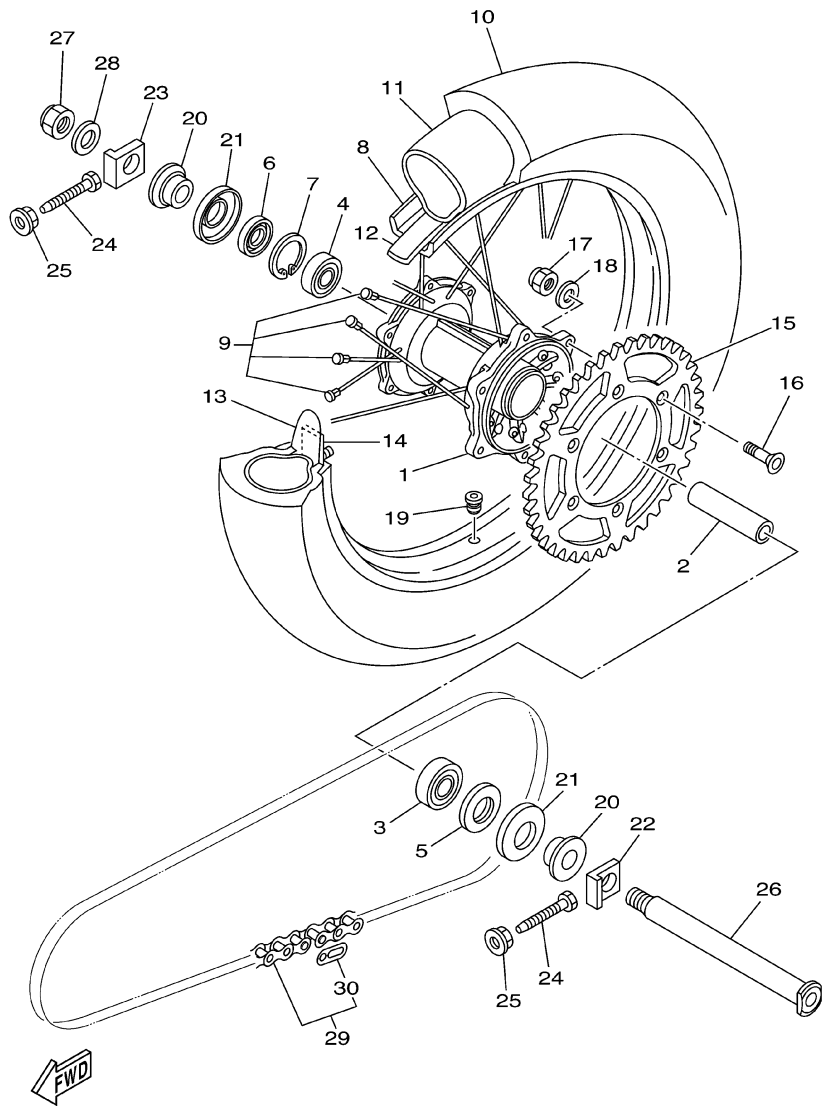

5NY1100-A270

REF. NO.	PART NO.	DESCRIPTION	5NY1	5NY2	5NY3	5NY4	REMARKS
1	5ET-25311-00	HUB, REAR	1	1	1	1	
2	5ET-25317-00	SPACER, BEARING	1	1	1	1	
3	93306-27205	BEARING	1	1	1	1	
4	93306-07202	BEARING	1	1	1	1	
5	93106-30044	OIL SEAL	1	1	1	1	
6	93106-30045	OIL SEAL	1	1	1	1	
7	99009-45500	CIRCLIP	1	1	1	1	
8	94418-19601	RIM (1.85-19)	1	1	1	1	
9	5HD-25304-00	SPOKE SET, REAR	1	1	1	1	
10		TIRE (100/90-19 D755)	1				
11		TUBE(100/90-19 TR4 BTL)	1				
12	94321-19135	BAND, RIM(90-100/90-19)	1	1		1	
13	4XM-25394-00	SPACER, BEAD	1	1	1	1	
14	4XM-25364-00	DAMPER	1	1	1	1	
15	5NY-25449-00	SPROCKET, DRIVEN (49T)	1	1	1	1	STD
	5ET-25447-00	SPROCKET, DRIVEN (47T)	1	1	1	1	AP
	5NY-25448-00	SPROCKET, DRIVEN (48T)	1	1	1	1	AP
	5NY-25450-00	SPROCKET, DRIVEN (50T)	1	1	1	1	AP
	5NY-25451-00	SPROCKET, DRIVEN (51T)	1	1	1	1	AP
	5NY-25452-00	SPROCKET, DRIVEN (52T)	1	1	1	1	AP
16	90109-081G1	BOLT	6	6	6	6	
17	90185-08169	NUT, SELF-LOCKING	6	6	6	6	
18	90201-08326	WASHER, PLATE	6	6	6	6	

FIG. 27 REAR WHEEL

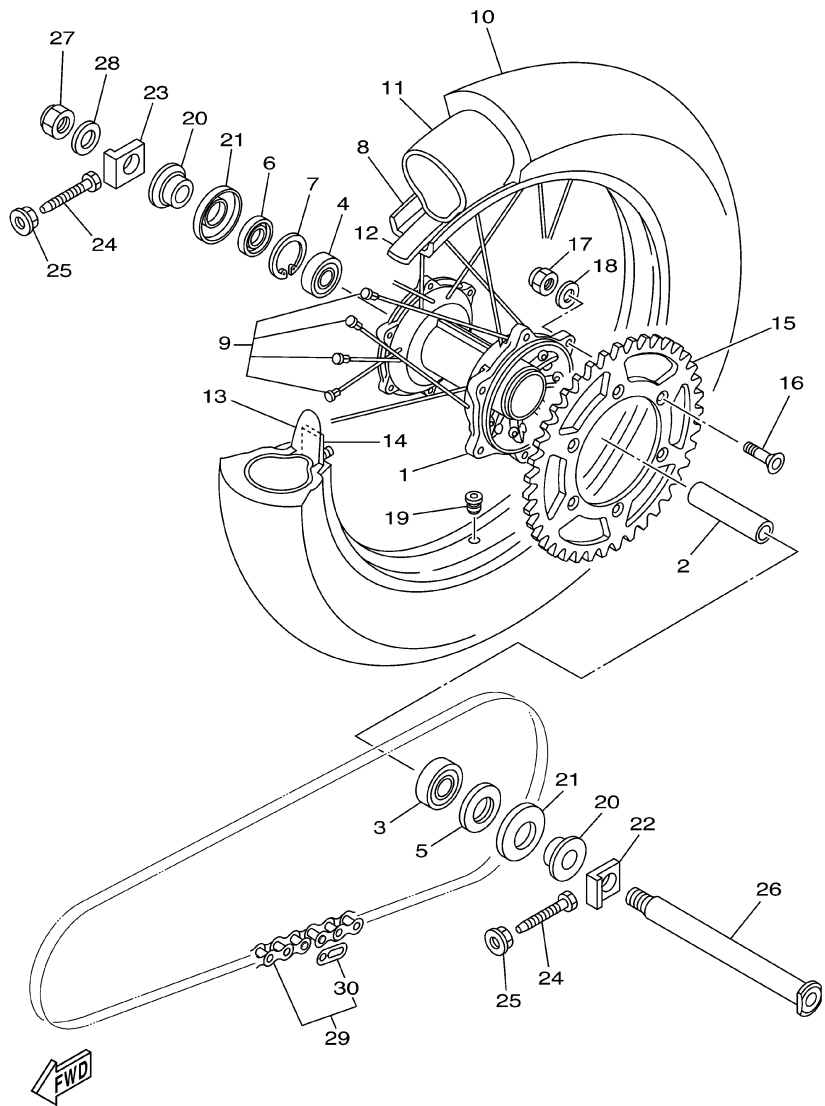

5NY1100-A270

REF. NO.	PART NO.	DESCRIPTION	5NY1	5NY2	5NY3	5NY4	REMARKS
19	90480-08608	GROMMET	1	1	1	1	
20	5NY-25383-00	COLLAR, WHEEL	2	2	2	2	
21	5ET-25367-00	COVER, HUB DUST	2	2	2	2	
22	5NY-25388-00	PULLER, CHAIN 1	1	1	1	1	
23	5NY-25389-00	PULLER, CHAIN 2	1	1	1	1	
24	90101-08777	BOLT	2	2	2	2	
25	90179-08299	NUT	2	2	2	2	
26	5ET-25381-00	AXLE, WHEEL	1	1	1	1	
27	90185-20168	NUT, SELF-LOCKING	1	1	1	1	
28	90201-203U1	WASHER, PLATE	1	1	1	1	
29	9Y581-92111	CHAIN	1	1	1	1	
30	94681-68001	.JOINT, CHAIN	1	1	1	1	

FIG. 28 REAR BRAKE CALIPER

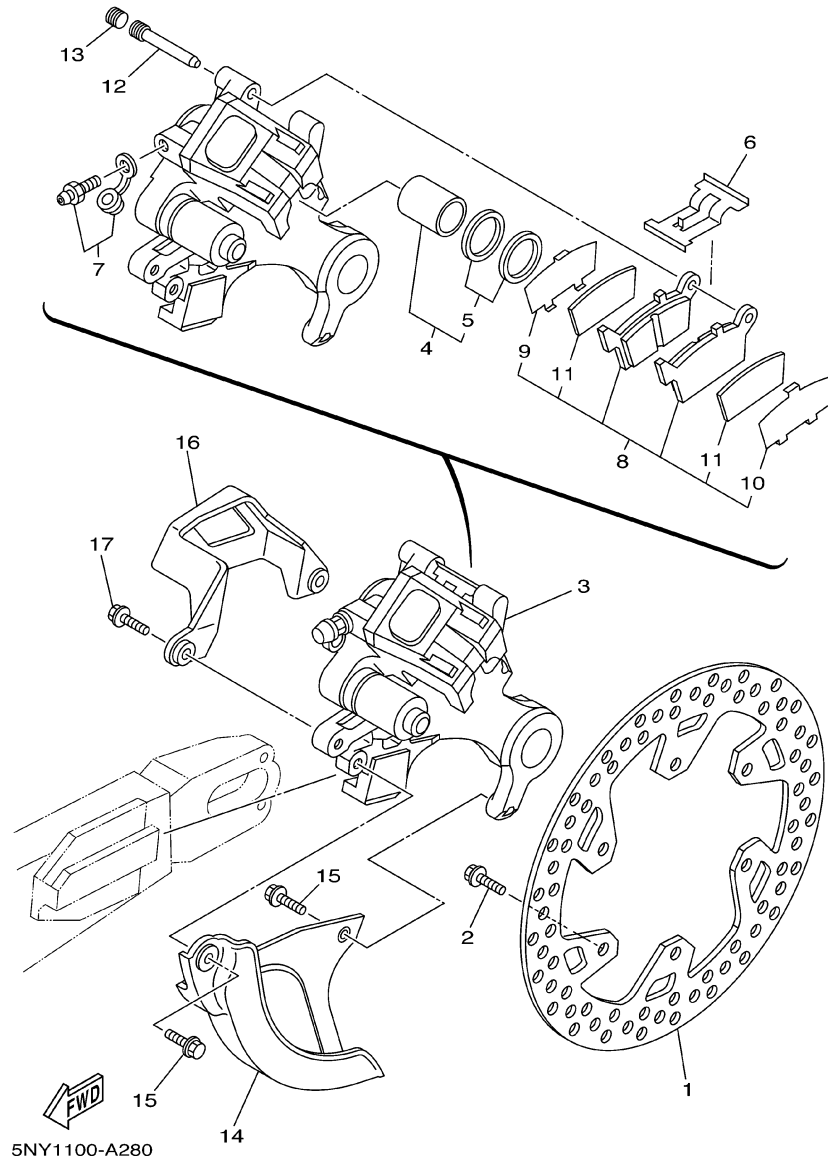

5NY1100-A280

REF. NO.	PART NO.	DESCRIPTION	5NY1	5NY2	5NY3	5NY4	REMARKS
1	5NY-2582W-00	DISC, REAR BRAKE 2	1	1	1	1	
2	90109-065G4	BOLT	6	6	6	6	
3	5NY-2580W-00	CALIPER ASSY, REAR 2	1		1	1	
4	5ET-W0057-50	.PISTON ASSY, CALIPER	1	1	1	1	
5	5ET-W0047-50	..CALIPER SEAL KIT	1	1	1	1	
6	5DH-25919-50	..SUPPORT, PAD	1	1	1	1	
7	1UY-W0048-50	..BLEED SCREW KIT	1	1	1	1	
8	5GR-W0046-00	..BRAKE PAD KIT 2	1		1	1	
9	5DH-25828-50	..SHIM, CALIPER	1	1	1	1	
10	5DH-25827-50	..SHIM, CALIPER	1	1	1	1	
11	5GR-22898-50	..INSULATOR, HEAT	2	2	2	2	
12	8CR-25924-00	..PIN, PAD	1	1	1	1	
13	5DH-25916-00	..PLUG	1	1	1	1	
14	5DH-25718-01	PROTECTOR, DISK BRAKE	1	1	1	1	
15	95027-06012	BOLT, FLANGE	2	2	2	2	
16	4GY-27491-00	PROTECTOR	1	1	1	1	
17	95027-06016	BOLT, FLANGE	2	2	2	2	

FIG. 29 STEERING HANDLE. CABLE

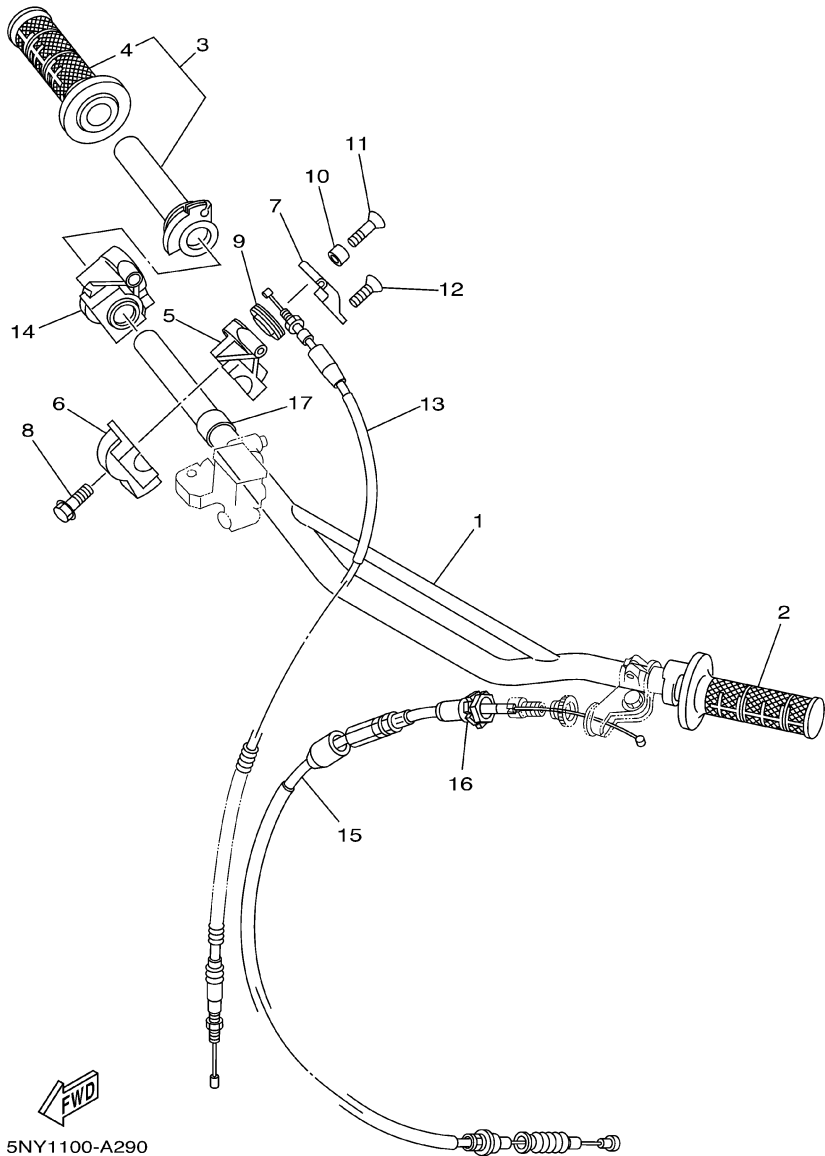

5NY1100-A290

REF. NO.	PART NO.	DESCRIPTION	5NY1	5NY2	5NY3	5NY4	REMARKS
1	5NY-26111-00	HANDLEBAR	1		1	1	
2	4GY-26241-00	GRIP	1	1	1	1	
3	4XM-26240-00	GRIP ASSY	1	1	1	1	
4	4GY-26242-00	.GRIP (RIGHT)	1	1	1	1	
5	4SS-26281-00	CAP, GRIP UPPER	1	1	1	1	
6	4SS-26282-10	CAP, GRIP LOWER	1	1	1	1	
7	4SS-2628H-00	CAP, WIRE	1	1	1	1	
8	95027-06025	BOLT, FLANGE	2	2	2	2	
9	5NY-26273-00	ROTOR	1	1	1	1	
10	4SS-26259-00	COLLAR	1	1	1	1	
11	4SS-26256-00	SCREW, GRIP END	1	1	1	1	
12	4SS-2632G-00	SCREW	1	1	1	1	
13	5MV-26311-00	CABLE, THROTTLE 1	1	1	1	1	
14	4SS-26287-01	COVER, CAP GRIP	1	1	1	1	
15	5HD-26335-00	CABLE, CLUTCH	1	1	1	1	
16	5HD-26342-00	BOOT, CABLE	1	1	1	1	
17	90387-227H7	COLLAR	1	1	1	1	

FIG. 30 FRONT MASTER CYLINDER

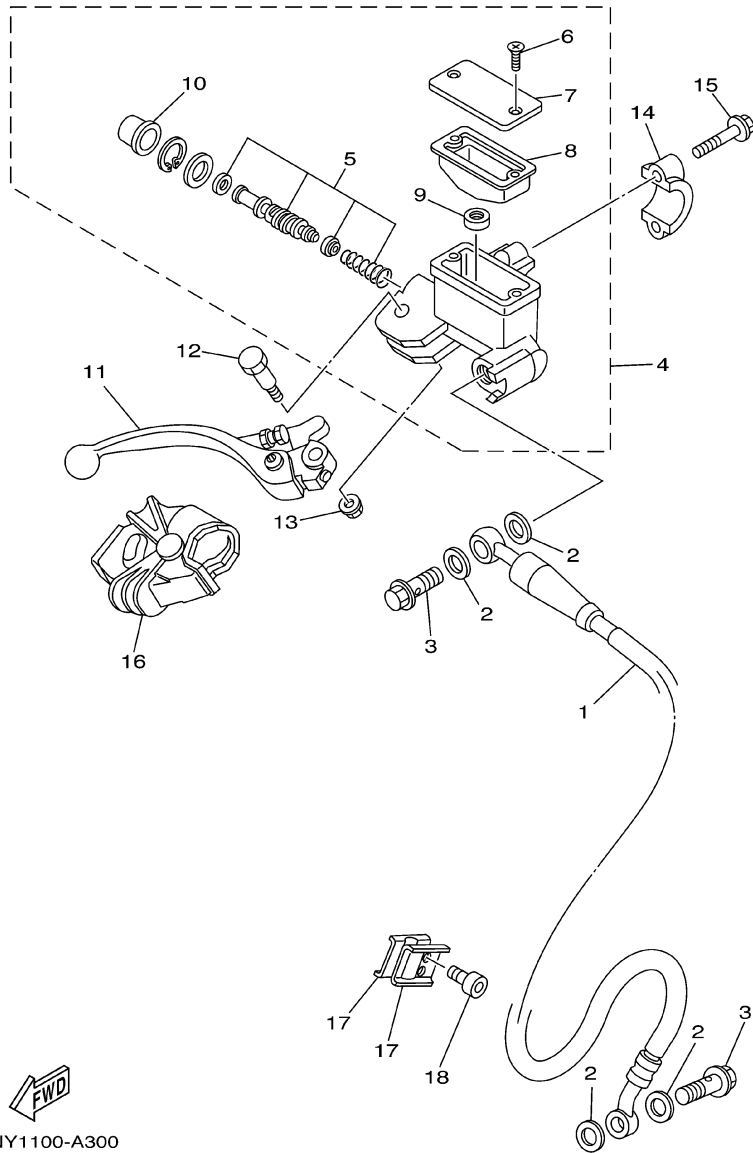

5NY1100-A300

REF. NO.	PART NO.	DESCRIPTION	5NY1	5NY2	5NY3	5NY4	REMARKS
1	5ET-25872-00	HOSE, BRAKE 1	1				
2	90201-10118	WASHER, PLATE	4	4	4	4	
3	90401-10168	BOLT, UNION	2	2	2	2	
4	5NY-W2587-01	MASTER CYLINDER SUB ASSY	1	1	1	1	
5	5NY-W0041-00	.CYLINDER KIT, MASTER	1	1	1	1	
6	98706-04012	.SCREW, FLAT HEAD	2	2	2	2	
7	5MV-25852-01	.CAP, RESERVOIR	1	1	1	1	
8	56A-25854-00	.DIAPHRAGM, RESERVOIR	1	1	1	1	
9	8CR-25715-00	.SEPARATOR ASSY	1	1	1	1	
10	5NY-25868-00	.BOOT, MASTER CYLINDER	1	1	1	1	
11	5MV-83922-00	LEVER 2	1	1	1	1	
12	5MV-2589F-00	BOLT, LEVER	1	1	1	1	
13	95701-06500	NUT, FLANGE	1	1	1	1	
14	5MV-25867-00	BRACKET, MASTER CYLINDER	1	1	1	1	
15	5MV-25833-00	BOLT, FITTING	2	2	2	2	
16	5NY-26372-00	COVER, HANDLE LEVER 1	1	1	1	1	
17	90465-16258	CLAMP	2	2	2	2	
18	91317-06014	BOLT	2	2	2	2	

FIG. 31 STAND, FOOTREST

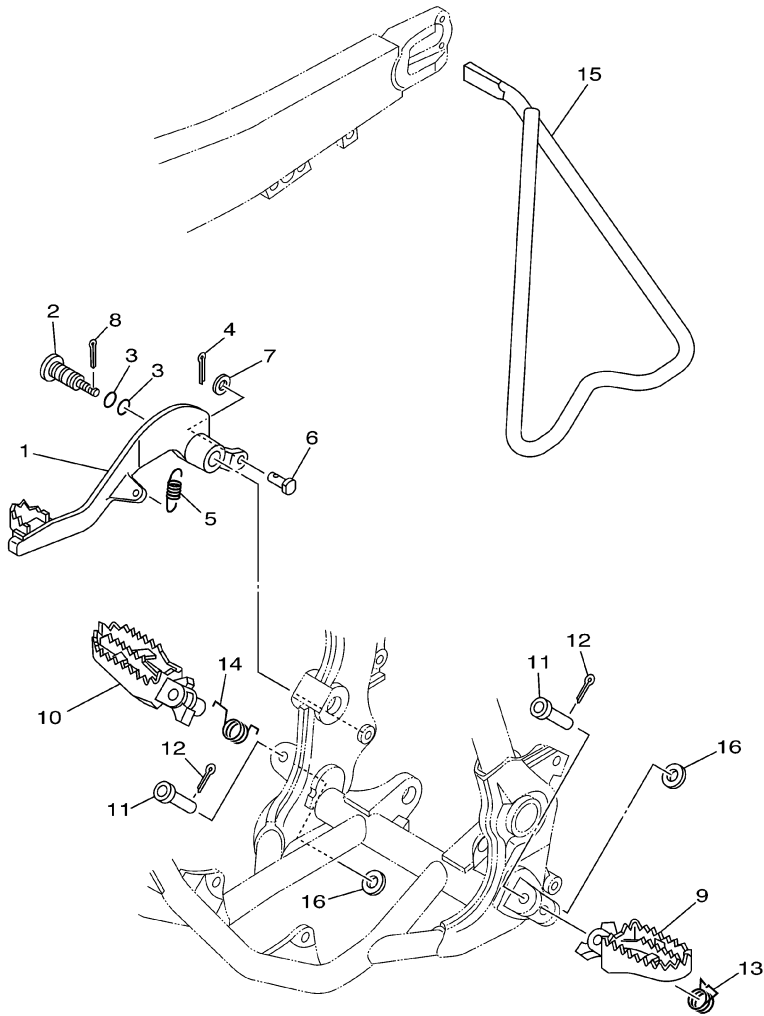

REF. NO.	PART NO.	DESCRIPTION	5NY1	5NY2	5NY3	5NY4	REMARKS
1	4XM-27200-00	PEDAL, BRAKE	1	1	1	1	
2	5JG-27217-00	BOLT	1	1	1	1	
3	93210-11073	O-RING	2	2	2	2	
4	91401-20012	PIN, COTTER	1	1	1	1	
5	90506-16500	SPRING, TENSION	1	1	1	1	
6	90240-08120	PIN, CLEVIS	1	1	1	1	
7	90201-08089	WASHER, PLATE	1	1	1	1	
8	90468-16191	CLIP	1	1	1	1	
9	5ET-27411-00	FOOTREST 1	1	1	1	1	
10	5ET-27421-00	FOOTREST 2	1	1	1	1	
11	90240-10142	PIN, CLEVIS	2	2	2	2	
12	91401-25015	PIN, COTTER	2	2	2	2	
13	90508-282B8	SPRING, TORSION	1	1	1	1	
14	90508-282B9	SPRING, TORSION	1	1	1	1	
15	5ET-27311-00	STAND, SIDE	1	1	1	1	
16	90201-10119	WASHER, PLATE	2	2	2	2	



5NY1100-A310

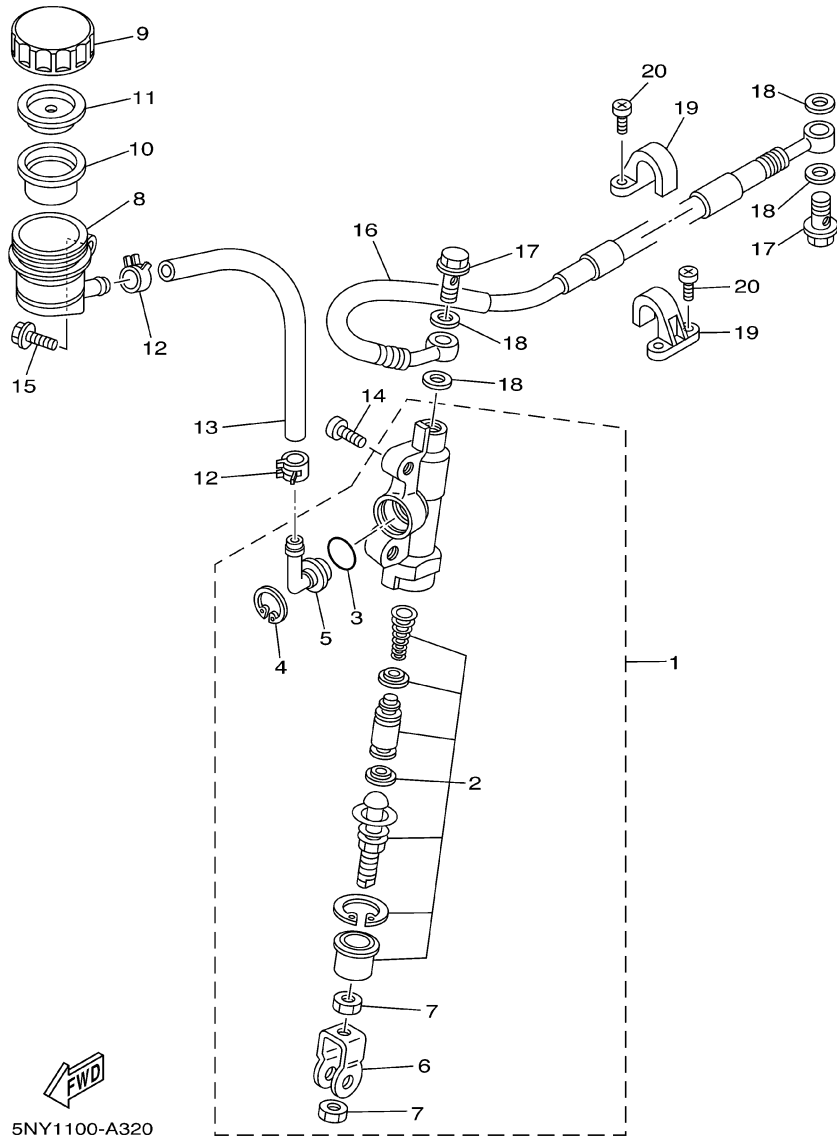

5NY1100-A320

FIG. 32 REAR MASTER CYLINDER

REF. NO.	PART NO.	DESCRIPTION	5NY1	5NY2	5NY3	5NY4	REMARKS
1	3SP-2583V-00	RR. MASTER CYLINDER ASSY.	1	1	1	1	
2	4SS-W0042-50	.CYLINDER KIT, MASTER	1	1	1	1	
3	93210-15620	.O-RING	1	1	1	1	
4	2VN-25866-00	.CIRCLIP	1	1	1	1	
5	2VN-2582A-50	.JOINT	1	1	1	1	
6	3SP-27222-00	.JOINT	1	1	1	1	
7	4SS-27218-00	.NUT	2	2	2	2	
8	4EW-25894-00	TANK, RESERVOIR	1	1	1	1	
9	3XP-25852-50	CAP, RESERVOIR	1	1	1	1	
10	2VN-25854-00	DIAPHRAGM, RESERVOIR	1	1	1	1	
11	2VN-25855-00	BUSH,DIAPHRAGM	1	1	1	1	
12	90467-12053	CLIP	2	2	2	2	
13	90445-137H9	HOSE	1	1	1	1	
14	92014-06016	BOLT, BUTTON HEAD	2	2	2	2	
15	95027-06012	BOLT, FLANGE	1	1	1	1	
16	5NY-25873-00	HOSE, BRAKE 2	1	1	1	1	
17	90401-10172	BOLT, UNION	2	2	2	2	
18	90201-10118	WASHER, PLATE	4	4	4	4	
19	2VM-25876-00	HOLDER, BRAKE HOSE 2	2	2	2	2	
20	90157-05095	SCREW, PAN HEAD	4	4	4	4	

FIG. 33 GENERATOR

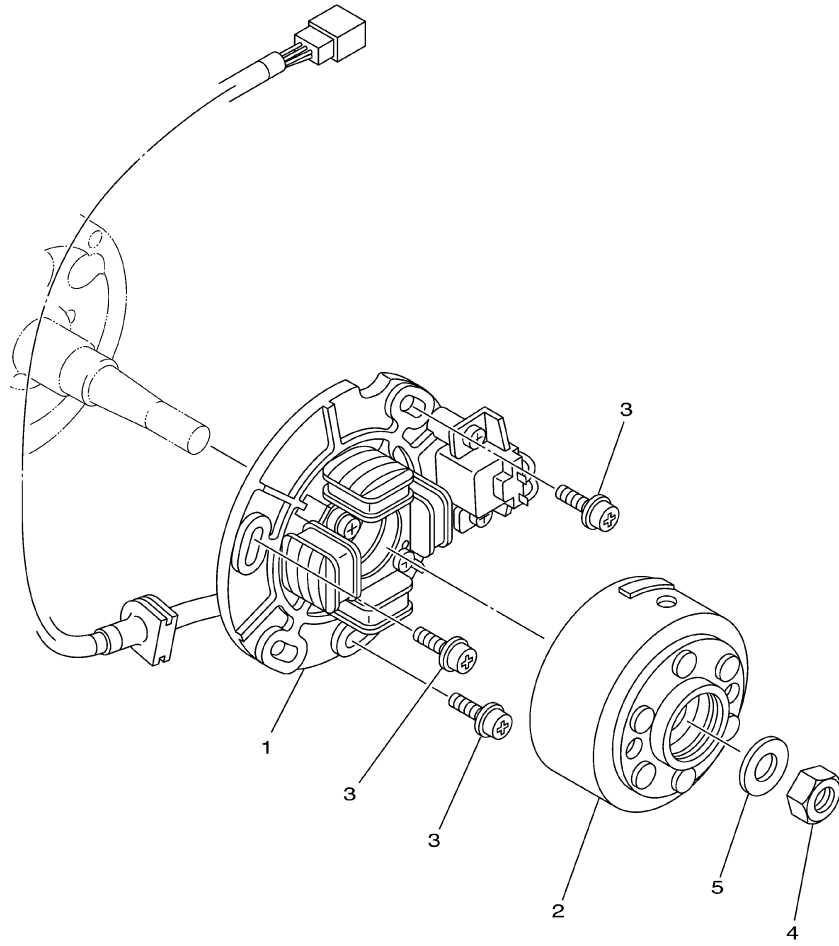

REF. NO.	PART NO.	DESCRIPTION	5NY1	5NY2	5NY3	5NY4	REMARKS
1	4SS-85560-01	BASE ASSY	1	1	1	1	
2	5CU-85550-11	ROTOR ASSY	1	1	1	1	
3	90149-06011	SCREW	3	3	3	3	
4	95317-10600	NUT	1	1	1	1	
5	90201-10591	WASHER, PLATE	1	1	1	1	

5NY1100-A330

FIG. 34 HANDLE SWITCH. LEVER

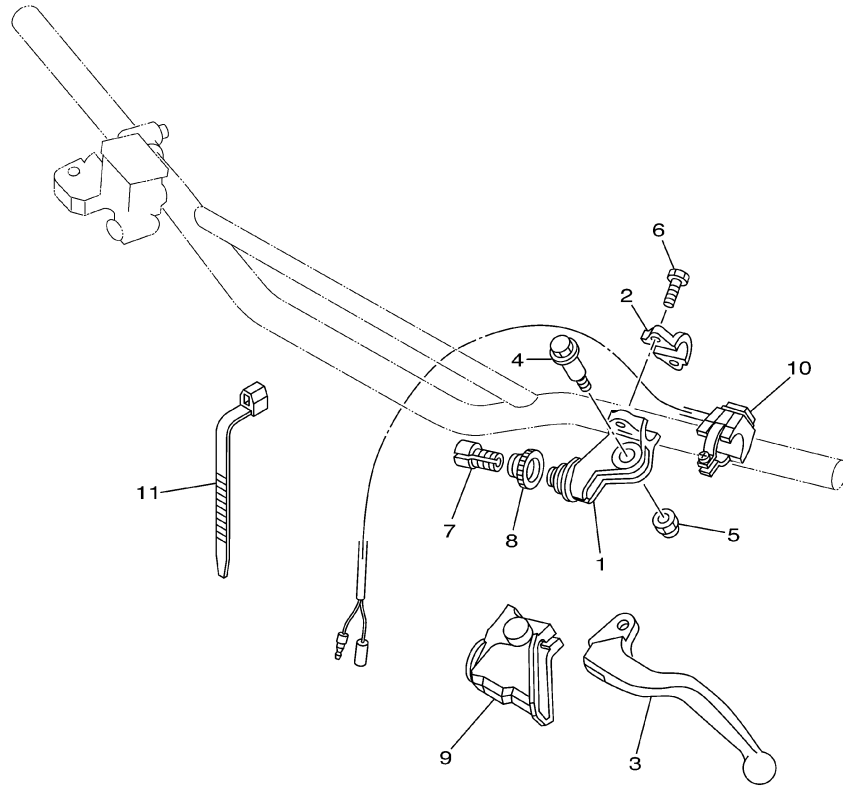

REF. NO.	PART NO.	DESCRIPTION	5NY1	5NY2	5NY3	5NY4	REMARKS
1	5HD-82911-00	HOLDER, LEVER 1	1	1	1	1	
2	38V-82913-00	HOLDER, LEVER LOWER 1	1	1	1	1	
3	5MV-83912-00	LEVER 1	1	1	1	1	
4	90109-06027	BOLT	1	1	1	1	
5	95607-06100	NUT, U	1	1	1	1	
6	97007-05016	BOLT	2	2	2	2	
7	5HD-26337-00	BOLT, ADJUSTING	1	1	1	1	
8	5HD-83951-00	BOLT, CABLE ADJUSTING	1	1	1	1	
9	5HD-26372-00	COVER, HANDLE LEVER 1	1	1	1	1	
10	23X-83976-00	SWITCH, HANDLE 1	1	1	1	1	
11	90464-13077	CLAMP	2	2	2	2	



5NY1100-A340

FIG. 35 ELECTRICAL 1

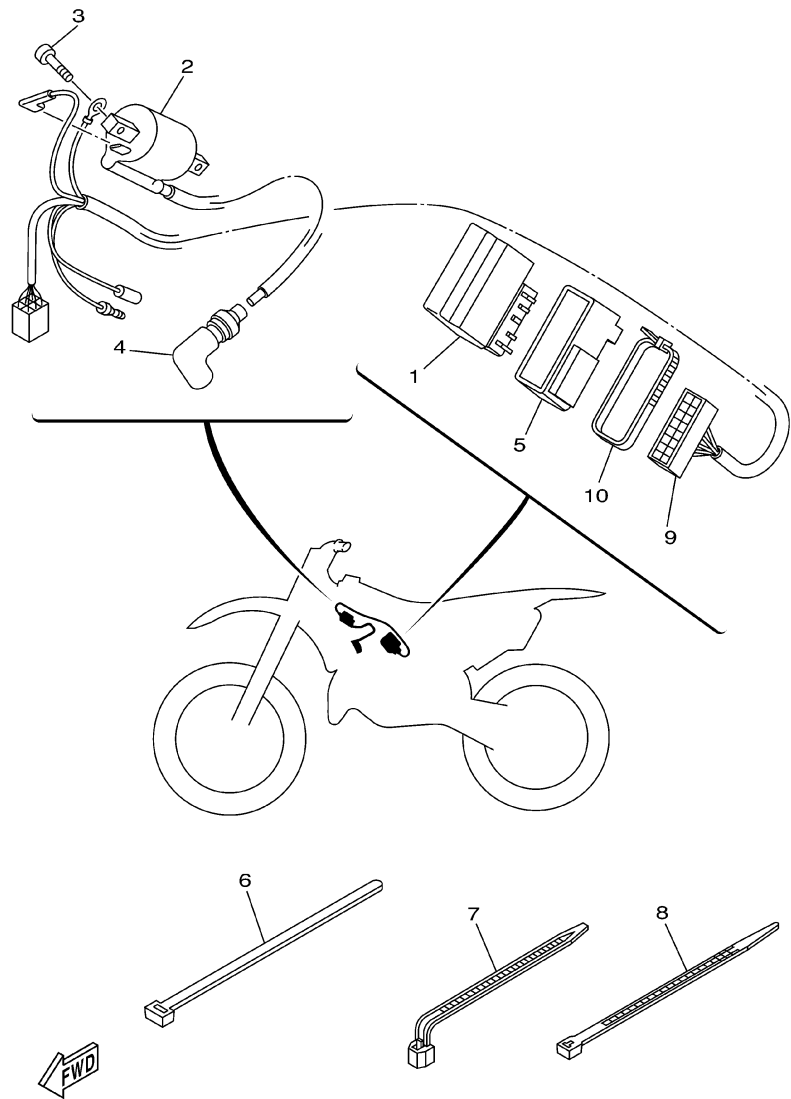

REF. NO.	PART NO.	DESCRIPTION	5NY1	5NY2	5NY3	5NY4	REMARKS
1	5NY-85540-00	C.D.I. UNIT ASSY	1		1	1	
2	4SS-82310-00	IGNITION COIL ASSY	1	1	1	1	
3	95027-06016	BOLT, FLANGE	2	2	2	2	
4	8DG-82370-00	PLUG CAP ASSY	1	1	1	1	
5	5NY-85546-00	BAND	1	1	1	1	
6	90464-50255	CLAMP	2	2	2	2	
7	90464-13073	CLAMP	1	1	1	1	
8	90465-13275	CLAMP	2	2	2	2	
9	5NY-82509-00	WIRE, SUB LEAD	1	1	1	1	
10	90460-15126	CLAMP, HOSE	1	1	1	1	

FIG. 36 ALTERNATE (CHASSIS)

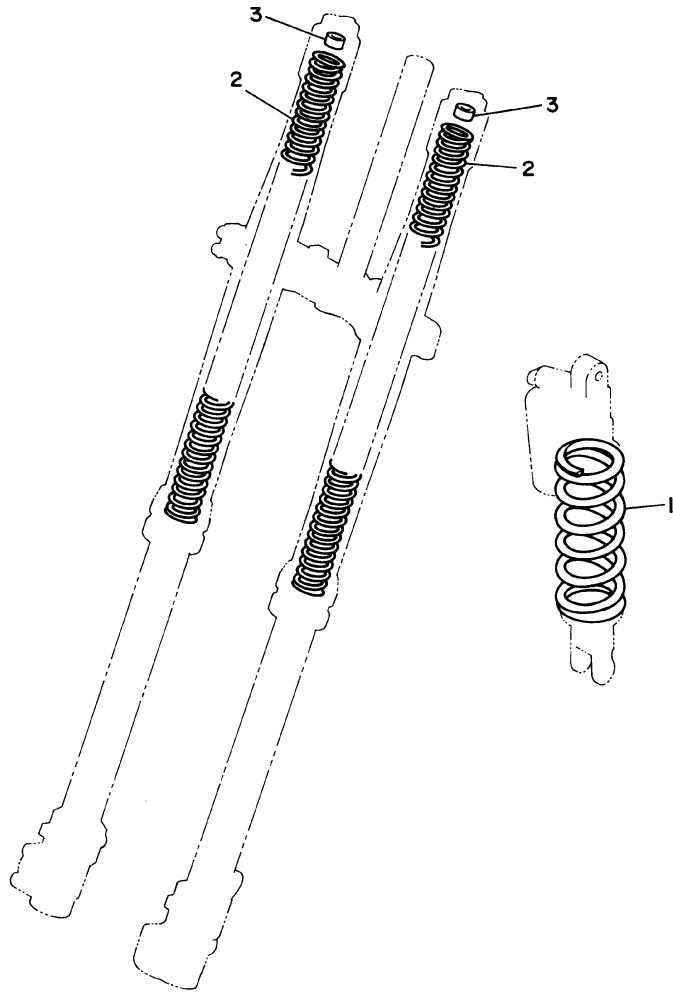

3XJI100-1360

REF. NO.	PART NO.	DESCRIPTION	5NY1	5NY2	5NY3	5NY4	REMARKS
1	5DH-22212-10	SPRING (K=4.6)	1	1	1	1	AP
	5DH-22212-20	SPRING (K=4.8)	1	1	1	1	AP
	5DH-22212-30	SPRING (K=5.0)	1	1	1	1	AP
	5DH-22212-40	SPRING (K=5.2)	1	1	1	1	AP
	5DH-22212-50	SPRING (K=5.4)	1	1	1	1	AP
	5DH-22212-60	SPRING (K=5.6)	1	1	1	1	AP
	5DH-22212-70	SPRING (K=4.4)	1	1	1	1	AP
	5ET-22212-10	SPRING (K=APPROX.5.0)	1	1	1	1	AP
	5ET-22212-20	SPRING (K=APPROX.4.6)	1	1	1	1	AP
	5ET-22212-30	SPRING (K=APPROX.5.2)	1	1	1	1	AP
	5ET-22212-40	SPRING (K=APPROX.5.4)	1	1	1	1	AP
	5ET-22212-00	SPRING (K=APPROX.4.8)	1	1	1	1	AP
2	4SS-23141-10	SPRING, FRONT FORK (K=0.38)	2	2	2	2	AP
	4SS-23141-20	SPRING, FRONT FORK (K=0.39)	2	2	2	2	AP
	4SS-23141-30	SPRING, FRONT FORK (K=0.40)	2	2	2	2	AP
	4SS-23141-40	SPRING, FRONT FORK (K=0.41)	2	2	2	2	AP
	4SS-23141-50	SPRING, FRONT FORK (K=0.42)	2	2	2	2	AP
	4SS-23141-60	SPRING, FRONT FORK (K=0.43)	2	2	2	2	AP
	4SS-23141-70	SPRING, FRONT FORK (K=0.44)	2	2	2	2	AP
	5ET-23141-00	SPRING (K=APPROX.0.41)	2	2	2	2	AP
	5ET-23141-10	SPRING (K=APPROX.0.43)	2	2	2	2	AP
	5ET-23141-20	SPRING (K=APPROX.0.40)	2	2	2	2	AP
	5ET-23141-30	SPRING (K=APPROX.0.42)	2	2	2	2	AP
	5ET-23141-40	SPRING (K=APPROX.0.44)	2	2	2	2	AP
3	4SS-23364-L0	COLLAR 2	1	1	1	1	UN

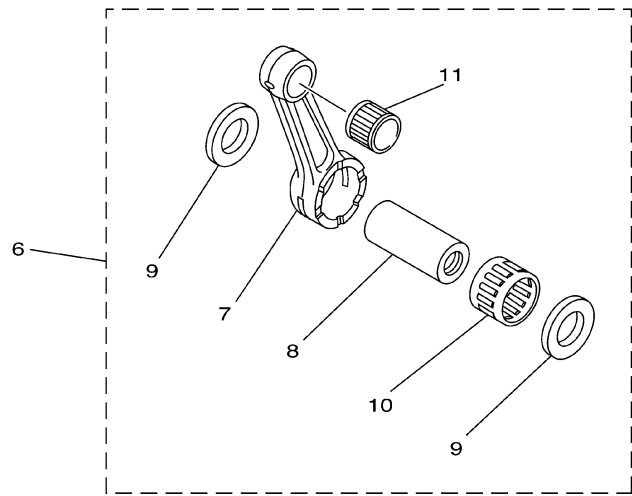
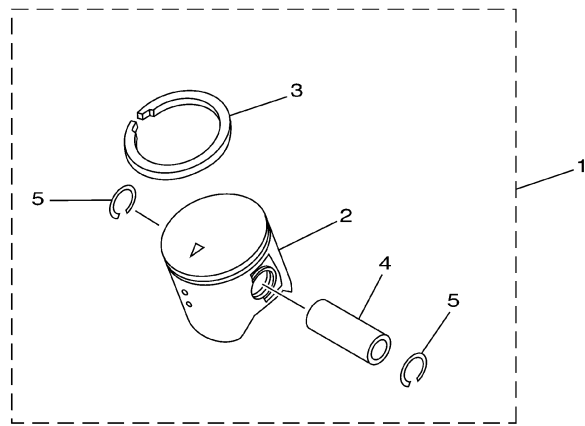

FIG. 37 OPTIONAL PARTS 1

REF. NO.	PART NO.	DESCRIPTION	5NY1	5NY2	5NY3	5NY4	REMARKS
1	N/A						
2	5NY-11631-00-B0	.PISTON (STD)	1	1	1	1	
3	5NY-11611-00	.RING, PISTON	1	1	1	1	
4	4XM-11633-10	.PIN, PISTON	1	1	1	1	
5	93450-16068	.CIRCLIP	2	2	2	2	
6	N/A						
7	5MV-11651-00	.ROD, CONNECTING	1	1	1	1	
8	3JD-11681-10	.PIN, CRANK 1	1	1	1	1	
9	90209-22071	.WASHER	2	2	2	2	
10	93310-522P7	.BEARING	1	1	1	1	
11	93310-21510	.BEARING	1	1	1	1	



5NY1100-A370

NUMERICAL INDEX

PARTNO.	GRID NO.	PARTNO.	GRID NO.	PARTNO.	GRID NO.	PARTNO.	GRID NO.	PARTNO.	GRID NO.	PARTNO.	GRID NO.
5NY-W0041-00	D - 14	4JY-11991-01	B - 3	284-14116-F6	B - 10	5NY-14459-00	B - 8	5NY-17421-00	C - 4	5MV-22176-00	C - 13
4SS-W0042-50	E - 2	4JY-11993-01	B - 3	284-14116-F7	B - 10	1FN-14565-00	B - 9	4SS-18101-10	C - 7	3JD-22178-10	C - 8
5DH-W0045-10	D - 9	4JY-11995-00	B - 3	4PE-14131-00	B - 9	5NY-14610-00	B - 13	4SS-18110-00	C - 7	4EW-22178-00	C - 8
5GR-W0046-00	D - 12	5NY-1240A-00	B - 7	87M-14137-00	B - 11	4JY-14615-00	B - 13	5MV-18122-00	C - 7	5MV-22184-00	C - 13
5MV-W0046-00	D - 12	4JY-12422-01	B - 6	4KM-14142-20	B - 10	5MV-14642-00	B - 13	5HD-18140-00	C - 6	4XM-22199-00	C - 11
3JD-W0047-00	D - 9	4JY-12428-00	B - 6	4KM-14142-22	B - 10	5NY-1469A-00	B - 13	4JY-18172-00	C - 7	5NY-22201-00	C - 13
5ET-W0047-50	D - 12	5DH-12451-00	B - 6	4KM-14142-25	B - 11	5NY-14753-00	B - 13	3XJ-18173-00	C - 7	5NY-22201-10	C - 13
1UY-W0048-50	D - 12	5DH-12459-01	B - 6	4KM-14142-27	B - 11	5CU-14771-00	B - 13	3XJ-18178-00	C - 7	5NY-22201-20	C - 13
	D - 9	5NY-12461-00	B - 7	4KM-14142-30	B - 10	565-14771-00	B - 13	3XJ-18182-00	C - 7	5NY-22201-30	C - 13
4EW-W0057-00	D - 9	5HD-12462-00	B - 7	4KM-14142-32	B - 11	5NY-15111-00	B - 14	3XJ-18184-00	C - 7	5NY-22201-40	C - 13
5ET-W0057-50	D - 12	5NY-12481-00	B - 7	4KM-14142-35	B - 11	3R4-15118-00	B - 14	4EW-18185-00	C - 7	5NY-22210-00	C - 13
5NY-W2587-01	D - 14	5NY-12482-00	B - 7	4KM-14142-37	B - 11	5NY-15121-00	B - 14	5NY-18511-00	C - 6	5NY-22210-10	C - 13
5MV-11111-00	B - 2	5NY-12483-00	B - 7	4KM-14142-40	B - 11	3Y1-15363-00	B - 15	5NY-18512-00	C - 6	5NY-22210-20	C - 13
4JY-11166-00	B - 2	5NY-12484-00	B - 7	137-14143-78	B - 11	1LX-15383-00	C - 4	5NY-18513-00	C - 6	5NY-22210-30	C - 13
5HD-1131D-10	B - 2	353-13115-01	B - 14	137-14143-80	B - 11	4XM-15383-00	C - 4	4EX-18531-00	C - 6	5NY-22210-40	C - 13
4SS-1131M-00	B - 2	5MV-13565-10	B - 8	137-14143-82	B - 11	4JY-15411-00	B - 15	4EX-18535-00	C - 6	5DH-22212-10	C - 13
5HD-1131V-00	B - 2	5MV-13610-00	B - 8	137-14143-84	B - 11	4EX-15421-00	B - 15	5NY-18541-00	C - 6		E - 6
5NY-11311-00	B - 2	5MV-13613-00	B - 8	137-14143-86	B - 11	4JY-15431-13	B - 15	5DH-18562-00	C - 6	5DH-22212-20	E - 6
5HD-1132D-10	B - 2	5MV-13616-00	B - 8	137-14143-88	B - 11	4JY-15451-10	B - 15	5NY-21101-00	C - 8	5DH-22212-30	E - 6
5DH-11351-01	B - 2	5MV-13625-00	B - 8	137-14143-90	B - 11	4JY-15462-00	B - 15	5NY-21190-00	C - 8	5DH-22212-40	E - 6
4JY-11354-02	B - 2	5NY-14101-00	B - 9	137-14143-92	B - 11	4JY-15463-01	B - 15	5NY-21274-00	C - 8	5DH-22212-50	E - 6
5MV-11400-00	B - 5	5NY-14101-10	B - 9	5MV-14146-00	B - 12	5NY-15490-00	B - 15	5HD-2135F-00	C - 12	5DH-22212-60	E - 6
5MV-11410-00	B - 5	5NY-14101-20	B - 9	51R-14146-00	B - 11	4DB-15620-03	C - 2	5NY-2135F-00	C - 12	5DH-22212-70	E - 6
5MV-11420-00	B - 5	4PE-14103-00	B - 9	2K6-14147-00	B - 9	4DB-15621-03	C - 2	5NY-21425-00	C - 8	5ET-22212-00	C - 13
5NY-11611-00	B - 5	3JD-14104-00	B - 9	5ET-14147-00	B - 11	1LX-15641-00	C - 2	5HD-21511-00	C - 9		E - 6
	E - 7	4PE-14107-38	B - 9	3MA-14159-00	B - 9	1LX-15651-00	C - 2	4XL-2153A-10	D - 4	5ET-22212-10	E - 6
5NY-11630-00	E - 7	5NY-14112-55	B - 11	5ET-1416A-00	B - 11	1LX-15660-03	C - 2	4ES-2153E-01	C - 9	5ET-22212-20	E - 6
5NY-11631-00-A0	B - 5	5NY-14112-57	B - 11	3JE-14171-00	B - 9	3XJ-16111-00	C - 3	5NY-21610-00	C - 9	5ET-22212-30	E - 6
5NY-11631-00-B0	B - 5	5NY-14112-60	B - 11	5ET-14181-10	B - 12	5NY-16150-00	C - 3	5NY-2163G-00	C - 9	5ET-22212-40	E - 6
	E - 7	5ET-14115-00	B - 9	5NY-14181-00	B - 12	3XJ-16181-00	C - 3	5BE-21642-00	C - 9	3SP-22213-00	C - 13
5NY-11631-00-C0	B - 5	248-14116-F4	B - 10	5ET-14185-00	B - 9	3XJ-16321-00	C - 3	5NY-21711-00	C - 10	5DH-22214-00	C - 13
5NY-11631-00-D0	B - 5	248-14116-F5	B - 10	353-14186-00	B - 9	5DH-16321-00	C - 3	5NL-2172A-10	C - 10	5MV-22224-00	C - 13
4XM-11633-10	B - 5	284-14116-E0	B - 10	4PE-14194-00	B - 9	3XJ-16324-01	C - 3	5NY-21721-00	C - 10	4JX-22226-00	C - 13
	E - 7	284-14116-E1	B - 10	5MV-14194-00	B - 11	4XV-16340-01	C - 3	5NY-2173E-01	C - 10	3SP-22234-00	C - 13
5MV-11650-00	E - 7	284-14116-E2	B - 9	10V-14196-00	B - 9	5HD-16351-00	C - 3	5NY-2173F-01	C - 10	5NY-22241-00	C - 14
5MV-11651-00	B - 5	284-14116-E3	B - 10	2HH-14197-00	B - 11	3SB-16356-10	C - 3	5NY-21730-00	C - 10	5DH-22253-00	C - 13
	E - 7		B - 9	5ET-14197-00	B - 9	5NY-16371-00	C - 3	5NY-21740-00	C - 10	5MV-22253-00	C - 13
3JD-11681-10	B - 5	284-14116-E4	B - 10	5MV-14216-00	B - 12	4EX-16382-10	B - 15	3JD-21748-00	C - 9	5NY-22355-00	C - 11
	E - 7		B - 9	5ET-14261-01	B - 9	5NY-17121-00	C - 4	5MV-2175C-00	C - 10	4EW-22474-00	C - 13
4SS-11832-00	B - 2	284-14116-E5	B - 9	5HD-14261-00	B - 9	5NY-17131-00	C - 4	5NY-22110-00	C - 11	3JE-22475-00	C - 13
5CU-11911-00	B - 4	284-14116-E6	B - 10	5MV-14261-00	B - 12	5NY-17141-00	C - 4	5NY-22121-00	C - 11	5NY-22475-00	C - 13
5CU-11912-00	B - 4	284-14116-E7	B - 10	5NY-14401-00	B - 8	5NY-17151-00	C - 4	5NY-22122-00	C - 12	5GR-22898-50	D - 12
4JY-11915-01	B - 4	284-14116-F0	B - 10	5NY-14417-00	B - 8	5NY-17211-00	C - 4	4XM-22128-00	C - 11	5NY-23102-00	D - 2
5X4-11921-02	B - 4	284-14116-F1	B - 10	5NY-14442-00	B - 8	5NY-17221-00	C - 4	5NY-22141-00	C - 11	5NY-23102-10	D - 2
3JE-11922-01	B - 4	284-14116-F2	B - 10	4XM-14451-00	B - 8	5NY-17231-00	C - 4	5MV-22151-00	C - 11	5NY-23102-20	D - 2
5CU-11952-00	B - 4	284-14116-F3	B - 10	5NY-14453-00	B - 8	5NY-17241-00	C - 4	5JG-22156-00	C - 11	5NY-23103-00	D - 2
5NY-11953-00	B - 4	284-14116-F4	B - 10	5NY-14455-00	B - 8	5NY-17251-00	C - 4	5NY-2217A-00	C - 11	5NY-23103-10	D - 3
4SS-11990-00	B - 4	284-14116-F5	B - 10	3JD-14458-01	B - 8	5NY-17411-00	C - 4	5NY-2217F-00	C - 12	5NY-23103-20	D - 3

NUMERICAL INDEX

PARTNO.	GRID NO.	PARTNO.	GRID NO.	PARTNO.	GRID NO.	PARTNO.	GRID NO.	PARTNO.	GRID NO.	PARTNO.	GRID NO.
5BF-23110-L0	D - 3	5NY-2316A-L0	D - 3	5NY-25104-00	D - 8	5MV-2589F-00	D - 14	5NY-85540-10	E - 5	90179-06568	C - 11
5NY-23111-L0	D - 2	5NY-2316A-M0	D - 2	5NY-25111-00	D - 8	4EW-25894-00	E - 2	5NY-85546-00	E - 5	90179-08299	B - 2
	D - 3		D - 3	5NY-25117-00	D - 8	3SP-25914-51	D - 9	5CU-85550-11	E - 3		D - 11
5DH-23118-L0	D - 2	5NY-23170-L0	D - 2	5BE-25181-00	D - 8	5DH-25916-00	D - 12	4SS-85560-01	E - 3	90179-16226	C - 5
	D - 3		D - 3	5NY-25183-00	D - 8		D - 9	9Y581-92111	D - 11	90179-16672	D - 8
3JD-2312G-L0	D - 2	5NY-23170-M0	D - 2	5NY-25186-00	D - 8	5DH-25919-00	D - 9	90101-06664	C - 7	90179-28650	C - 15
	D - 3		D - 3	5HD-25304-00	D - 10	5DH-25919-50	D - 12	90101-08777	D - 11	90183-06023	B - 8
5DH-23120-L0	D - 2	5ET-23171-L0	D - 2	5ET-25311-00	D - 10	8CR-25924-00	D - 12	90105-06553	C - 6	90185-08055	C - 8
5ET-23125-L0	D - 2		D - 3	5ET-25317-00	D - 10	3SP-25926-51	D - 9	90105-06556	B - 14	90185-08169	C - 8
	D - 3	5DH-23183-00	C - 13	4XM-25364-00	D - 10	5DH-25933-00	D - 9	90105-08120	C - 8		D - 10
5HD-23136-L0	D - 2	509-23184-L0	C - 13	5ET-25367-00	D - 11	4XM-26111-00	D - 13	90105-08494	C - 8	90185-10060	C - 14
	D - 3	5DH-23195-L0	D - 2	5ET-25381-00	D - 11	5NY-26111-00	D - 13	90105-08659	D - 9	90185-14007	C - 12
5DH-2314E-00	D - 9		D - 3	5NY-25383-00	D - 11	4XM-26240-00	D - 13	90105-10323	C - 13	90185-16127	C - 11
5DH-2314F-L0	D - 4	5MV-23195-L0	D - 2	5NY-25388-00	D - 11	4GY-26241-00	D - 13	90105-10445	C - 3	90185-20168	D - 11
4SS-2314G-L0	D - 4		D - 3	5NY-25389-00	D - 11	4GY-26242-00	D - 13	90105-10733	C - 8	90201-03313	B - 8
5DH-2314H-00	D - 4	4EW-2331E-L1	D - 4	4XM-25394-00	D - 10	4SS-26256-00	D - 13	90109-06027	E - 4	90201-057H5	B - 4
5DH-2314J-00	D - 4	5DH-23340-M0	D - 3	5SF-25394-00	D - 8	4SS-26259-00	D - 13	90109-06418	B - 15	90201-06060	B - 13
4SS-23141-10	E - 6	4SS-23346-L0	D - 4	5ET-25447-00	D - 10	5NY-26273-00	D - 13	90109-065G4	D - 12		C - 2
4SS-23141-20	E - 6	5NY-23346-L0	D - 3	5NY-25448-00	D - 10	4SS-2628H-00	D - 13	90109-067F4	B - 8	90201-06071	B - 13
4SS-23141-30	E - 6	3SP-23356-L0	D - 4	5NY-25449-00	D - 10	4SS-26281-00	D - 13	90109-081G1	D - 10		C - 9
4SS-23141-40	E - 6	4SS-23364-L0	E - 6	5NY-25450-00	D - 10	4SS-26282-10	D - 13	90110-08096	C - 8	90201-06557	C - 9
4SS-23141-50	E - 6	4DA-23389-00	D - 4	5NY-25451-00	D - 10	4SS-26287-01	D - 13	90116-08318	B - 2	90201-080L8	B - 2
4SS-23141-60	E - 6	5HD-2339E-00	C - 15	5NY-25452-00	D - 10	5MV-26311-00	D - 13	90116-08388	B - 2	90201-08089	D - 15
4SS-23141-70	E - 6	5HD-23393-L0	D - 2	8CR-25715-00	D - 14	4SS-2632G-00	D - 13	90116-08394	B - 2	90201-083P5	B - 6
4XM-23141-L0	D - 2		D - 3	5DH-25718-01	D - 12	5HD-26335-00	D - 13	90119-05071	D - 4	90201-08326	D - 10
	D - 3	4EW-23416-00	C - 15	5MV-2580T-00	D - 9	5HD-26337-00	E - 4	90119-06038	B - 7	90201-086P8	C - 8
5ET-23141-L0	D - 2	5HC-23435-00	C - 15	5NY-2580W-00	D - 12	5HD-26342-00	D - 13	90119-06096	C - 9	90201-08730	C - 8
	D - 3	5NL-23435-00	C - 15	5NY-2580W-10	D - 12	5HD-26372-00	E - 4	90119-06192	B - 13	90201-08759	C - 3
5ET-23141-00	E - 6	3SP-23441-00	C - 15	5MV-2581T-00	D - 9	5NY-26372-00	D - 14		C - 9	90201-08784	B - 6
5ET-23141-10	E - 6	5HD-23485-10	C - 15	2VN-2582A-50	E - 2	4XM-27200-00	D - 15	90119-06214	D - 5	90201-10118	D - 14
5ET-23141-20	E - 6	5NY-24110-00	D - 5	5NY-2582W-00	D - 12	5JG-27217-00	D - 15	90119-06225	C - 15		E - 2
5ET-23141-30	E - 6	4EW-2412F-00	D - 5	5DH-25827-50	D - 12	4SS-27218-00	E - 2		C - 9	90201-10119	D - 15
5ET-23141-40	E - 6	24X-24144-00	D - 5	5DH-25828-50	D - 12	3SP-27222-00	E - 2	90119-08238	C - 10	90201-10591	E - 3
5DH-23142-L0	D - 2	3SP-24173-00	D - 5	3SP-2583V-00	E - 2	5ET-27311-00	D - 15	90122-06035	B - 8	90201-14740	C - 12
	D - 3	4SS-24181-00	D - 5	5MV-25833-00	D - 14	5ET-27411-00	D - 15	90149-06011	D - 5	90201-150U6	B - 4
5HD-23144-L0	D - 2	5NY-24182-00	D - 5	3XP-25852-50	E - 2	5ET-27421-00	D - 15		E - 3	90201-152H7	C - 2
	D - 3	5NY-24183-00	D - 5	5MV-25852-01	D - 14	4GY-27491-00	D - 12	90149-06327	D - 9	90201-15700	C - 4
5ET-23145-L0	D - 2	5NY-24186-00	D - 5	2VN-25854-00	E - 2	5ET-28166-00	C - 8	90151-04048	C - 11	90201-160F6	C - 11
	D - 3	5NY-24240-01	D - 5	56A-25854-00	D - 14	4SS-82310-00	E - 5	90151-06037	C - 4	90201-171G4	C - 2
4SS-23146-L0	D - 2	3XJ-24380-00	D - 5	2VN-25855-00	E - 2	8DG-82370-00	E - 5	90152-06010	C - 2	90201-203U1	D - 11
	D - 3	3JD-24500-01	D - 5	2VN-25866-00	E - 2	5NY-82509-00	E - 5	90157-05095	E - 2	90201-20611	C - 3
5DH-23149-L0	D - 2	4X8-24512-00	D - 5	5MV-25867-00	D - 14	5HD-82911-00	E - 4	90159-06016	C - 3		C - 4
	D - 3	5MV-24514-00	B - 11	5NY-25868-00	D - 14	38V-82913-00	E - 4	90159-06078	C - 10	90201-22555	C - 4
4SS-23153-L0	D - 2	3AJ-24534-00	D - 5	5ET-25872-00	D - 14	5MV-83912-00	E - 4		C - 6	90201-22793	C - 4
	D - 3	5NY-24610-00	D - 5	5HD-25872-00	D - 14	5MV-83922-00	D - 14	90159-06182	C - 10	90201-247L2	C - 15
4SS-23158-L0	D - 2	5NY-2470F-00	D - 7	5NY-83951-00	E - 2	5HD-83951-00	E - 4	90170-16326	C - 3	90201-286K9	C - 15
	D - 3	5NY-24728-00	D - 7	5DH-25875-00	D - 9	23X-83976-00	E - 4	90170-24373	C - 15	90202-05193	D - 5
5NY-2316A-L0	D - 2	5NY-24770-00	D - 7	2VM-25876-00	E - 2	5NY-85540-00	E - 5	90176-08026	B - 2	90209-06096	B - 8

NUMERICAL INDEX

PARTNO.	GRID NO.	PARTNO.	GRID NO.	PARTNO.	GRID NO.	PARTNO.	GRID NO.	PARTNO.	GRID NO.	PARTNO.	GRID NO.
90209-18135	C - 4	90464-13073	E - 5	92907-06100	D - 7	93332-00068	C - 15	95027-06020	B - 8	99530-10114	B - 15
90209-22071	B - 5	90464-13077	E - 4	92907-06600	B - 15	93332-00081	C - 15		C - 7	99590-10114	B - 2
	E - 7	90464-50255	E - 5	92907-08200	D - 9	93340-21008	C - 3	95027-06025	B - 13	99590-17016	B - 14
90215-16289	C - 3	90465-13152	D - 6	93102-12106	B - 6	93340-21505	B - 4		B - 15		
90215-20261	C - 5	90465-13275	D - 5	93102-12224	B - 15	93342-22217	C - 11		D - 13		
90240-08120	D - 15		E - 5	93102-17263	C - 2	93410-22039	C - 4	95027-06030	B - 15		
90240-10142	D - 15	90465-16258	D - 14	93102-20485	B - 5	93430-08053	C - 3		B - 6		
90267-32070	B - 8	90467-09006	B - 7	93102-26042	C - 4	93440-15012	C - 2		C - 9		
90280-03017	B - 5	90467-10008	D - 5	93102-26468	D - 8			95027-06040	B - 15		
90340-12059	B - 14	90467-12053	E - 2	93102-30008	B - 5	93450-16068	B - 5	95027-06045	B - 13		
90340-12144	B - 14	90467-13062	B - 2	93104-08040	B - 2			95027-06050	C - 11		
90387-06009	C - 9	90468-16191	D - 15		B - 4	93507-16020	B - 4	95027-06065	B - 6		
90387-06039	B - 13	90468-26048	C - 2	93106-22019	C - 11	93507-32009	C - 2	95027-08020	D - 9		
90387-0614M	B - 7	90480-08608	D - 11	93106-30044	D - 10	93603-14240	B - 4	95027-08035	C - 15		
90387-062W7	B - 13	90480-15528	B - 7	93106-30045	D - 10	93604-10011	B - 15	95027-08040	C - 15		
90387-063F7	C - 6	90480-16404	B - 13	93109-11073	B - 6				C - 8		
90387-063G3	B - 13	90480-16561	B - 13	93109-12012	C - 7	93612-16254	B - 14	95027-08055	C - 8		
90387-085E1	B - 4	90480-18549	D - 5	93109-20076	C - 11	9383A-12017	C - 5	95317-10600	E - 3		
90387-086N4	C - 8	90501-052G5	C - 7		C - 12	9383A-13031	C - 5	95607-06100	E - 4		
90387-08785	B - 3	90501-12081	C - 2	93109-28043	C - 11	9383A-14054	C - 5	95607-10200	C - 14		
90387-107T9	B - 4	90501-23391	C - 3	93210-11073	D - 15	94108-21011	D - 8		C - 8		
90387-152F2	B - 4	90501-26001	B - 4	93210-15171	C - 2	94108-2110Y	D - 8	95701-06500	D - 14		
90387-16005	C - 11	90506-16500	D - 15	93210-15620	E - 2	94108-2112Y	D - 8	95817-08050	C - 8		
90387-16007	C - 11	90507-20052	B - 13	93210-16314	B - 14	94110-1911A	D - 10	95817-10090	C - 11		
90387-167Y9	C - 11	90508-141B4	C - 3	93210-19123	B - 15	94110-1913B	D - 10	95827-06010	B - 7		
90387-18004	C - 11	90508-16134	B - 2	93210-63442	B - 2	94110-1916A	D - 10	95827-06012	D - 9		
90387-18005	C - 11	90508-261B7	C - 6	93210-90785	B - 2	94209-21229	D - 8	95827-06016	C - 10		
90387-18006	B - 14	90508-26450	C - 2	93300-60801	B - 4	94210-19222	D - 10	97007-05012	B - 4		
90387-20007	C - 3	90508-282B8	D - 15	93300-60804	C - 8	94210-19224	D - 10	97007-05016	B - 3		
90387-202A0	C - 5	90508-282B9	D - 15	93306-00105	B - 6	94227-21101	D - 8		E - 4		
90387-227H7	D - 13	90508-295A7	C - 7	93306-07202	D - 10	94309-21161	D - 8	97027-06012	C - 2		
90401-10168	D - 14	90560-12280	C - 7	93306-20431	C - 4	94316-19156	D - 10	97307-06012	D - 7		
90401-10172	E - 2	90560-17279	C - 2	93306-27205	D - 10	94321-19135	D - 10	97707-60016	C - 9		
90430-06014	B - 15	91A20-05065	B - 7	93306-30411	C - 4	94330-21084	D - 8	97801-03008	D - 5		
	B - 6	91317-04006	B - 4	93306-37204	B - 5	94416-21003	D - 8	98502-05014	B - 11		
90430-12227	B - 14	91317-04008	B - 2	93306-90403	D - 8	94418-19601	D - 10	98507-03006	B - 8		
90445-08605	B - 14	91317-05008	C - 11	93306-90504	C - 6	94681-68001	D - 11	98507-04008	B - 9		
90445-09104	D - 5	91317-05012	B - 2	93310-21510	B - 5	94702-00324	B - 2	98507-04014	B - 9		
90445-09220	D - 5	91317-06014	D - 14		E - 7	94709-00324	B - 2	98507-05012	B - 4		
90445-111J0	D - 5	91317-06045	B - 14	93310-225N0	C - 3	95027-06010	B - 15	98507-06016	B - 15		
90445-137H9	E - 2	91317-06055	B - 14	93310-522P7	B - 5		B - 6	98507-06030	B - 15		
90450-22017	B - 7	91317-06070	B - 14		E - 7		C - 11	98706-04012	D - 14		
90450-25037	B - 7	91401-20012	D - 15	93311-31515	C - 5	95027-06012	B - 13	98707-06025	D - 5		
90450-28014	B - 7	91401-25015	D - 15	93311-41530	C - 4		D - 12	98907-05016	B - 2		
90450-51070	B - 8	92014-06016	E - 2	93315-11206	B - 15		E - 2	98907-06025	D - 5		
90450-70072	B - 8	92017-06010	B - 13	93315-32053	C - 12	95027-06016	D - 12	99001-06600	B - 6		
90460-15126	E - 5	92907-03100	B - 8	93315-32056	C - 11		D - 5	99009-45500	D - 10		
90461-10136	B - 14	92907-05600	B - 3	93317-22262	C - 11		E - 5	99244-00200	C - 12		